

Fast-Response Multi-Hole Probes

- Embedded Sensors
- High Frequency Response
- Acoustic Correction Algorithm



Applications:

- Unsteady Bluff Body Wake Flows
- Atmospheric Turbulence
- Turbulent Boundary Layers
- Rotating Machinery

- Accurate Resolution of Velocity Vectors as High as 60° (for 5-Hole Probes) and 70° (for 7-Hole Probes)
- Standard Probe Designs for Air Applications, Custom Designs for Use in Water
- Flow Speeds from 5 m/s to 325 m/s, Mach 0.02 to Mach 0.95

Performance:

- Determination of Three Components of Instantaneous Flow Velocity, Plus Total and Static Pressure at Probe Tip
- Frequency Response up to 5 kHz Standard, Depending on Probe Geometry

Features:

- Available Probe Tip Diameters 3.2 mm, 2.4mm and 1.6 mm
- Multiple Standard Probe Geometries
- Standard Manufacturing Uses Stainless Steel Components for Rugged Construction

- Hemispherical or Conical Probe Tips
- Aeroprobe Expertise in Probe Design and Construction
- Pressure Sensors Embedded in the Probe for Increased Frequency Response
- ARC Acoustic Correction Algorithm for Tubing Response and Inertial Effects in Unsteady Flows, for use with Multiprobe and AeroAcquire

Calibrations

- High-Accuracy, 2000+ Point Aerodynamic Calibrations
- Complete Post-Calibration Error Analysis and Quality Control
- Acoustic Calibration of Probe Internal Pneumatic System to Determine Acoustic Response
- NIST-Traceable Calibration of Embedded Pressure Sensors

Introduction:

In dynamically changing flowfields, high-frequency-response flow diagnostics instrumentation is necessary. Aeroprobe's fast-response probes and supporting technology enable the simultaneous measurement of the three instantaneous components of velocity plus the static and total pressure at a measurement point, in dynamically changing flows. Fast-response probes are manufactured by embedding the pressure transducers within the multi-hole probe body, greatly increasing the frequency response of the probe.

There are five basic elements required for accurate flow measurement using a fast-response multi-hole probe: (1) The probe itself, which includes the amplified pressure sensors required to measure the port pressures (2) A set of accurate aerodynamic probe calibrations in steady flow, over the speed range of interest (3) Data acquisition hardware and software capable of digitizing the probe signals at a sufficient frequency (4) Processing software to correctly account for the effects of unsteady flow on the measured pressures, so that the actual tip pressures can be recovered from the measured data and (5) Reduction software to convert the actual pressures to velocities based on the calibration map. This document provides a description of Aeroprobe products and services that fulfill requirements (1), (2), (4) and (5) above.

Fast-Response Probes:

Because of the complexity of fast-response probes and because the design is often very closely tied to the application, the range of probe geometries is decreased compared with the conventional Aeroprobes. Designs are similar to the standard multi-hole probes, with slight modifications to embed the sensors.

All standard fast-response probes are five-hole or seven-hole models. Aeroprobe offers two basic fast-response probe models, SR (the standard fast-response probe) and ER (with elevated frequency response). For each probe model, there are two geometries: straight and L-shaped. These can be manufactured with either conical or hemispherical tips. Conical tips are typically manufactured with an included angle of 60°. Standard construction material is stainless steel, but all fast-response probes contain electronics and epoxies and are thus much more limited in temperature capability than the conventional Aeroprobes. Fast-response probes can be manufactured with tip diameters from 1.59 mm to 25.4 mm. Because small tip diameters result in decreased errors due to tip inertial effects in unsteady flow (see Estimation of Accuracy section below), Aeroprobe recommends using a 2.4mm tip diameter as a good combination of frequency response, spatial resolution and overall accuracy.

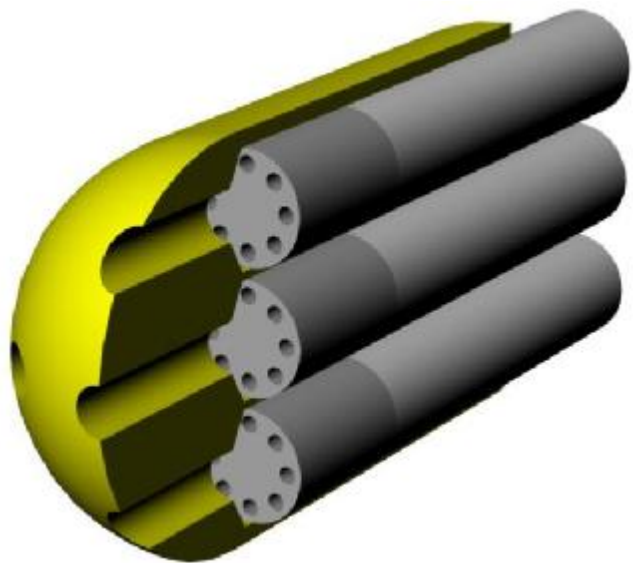

Cross-Sectional View of a Fast-Response Probe with Pressure Transducers Embedded in the Tip. This Can Be Accomplished for Probe Tips of at Least 12.7mm OD.

Fast-Response Probe Design:

The design of a fast-response probe is dictated by several factors: (1) Desired frequency response (2) Required pressure range (both static and dynamic) at which the probe will operate and (3) Desired probe geometry. The selection of a probe tip diameter and the pressure sensors is greatly influenced by these factors, and this is the most important part of the probe specification process.

Sensors are embedded in the probe at three different locations, depending on probe size and geometry. For larger probe tips and small sensors, it may be possible to place the sensors very close to the tip, giving the best frequency response. However, due to geometry restrictions, it is almost always more reasonable to place the sensors in the probe shaft. Large probes (tip diameters at least 12.7mm) with sensors at the tip are available as custom designs.

The SR probe models utilize board-mounted sensors that are placed within the 12.7mm OD shaft of the probes. This design provides a basic probe with good frequency-response characteristics. The ER probe models employ more capable pressure sensors embedded directly behind the tip section of the probe, providing elevated frequency response.

Due to restrictions inherent to the probe assembly, the L-shaped fast-response probes must have the drilled-elbow tip. Longer tip lengths are not possible in standard designs.

Amplification of Embedded Sensors:

Many of the sensors used in the fast-response probes have output of approximately 300 mV full scale. In order to minimize the effects of electrical noise, and to match input for data acquisition systems, Aeroprobe amplifies the signals within the probe. Thus, the output of the probe is an amplified analog voltage.

Discussion of Accuracy Associated with Use of Multi-Hole Probes in Unsteady Flow:

There are four major sources of error that are specific to unsteady measurement of velocities with a multi-hole probe. The first two sources of error are the same as for conventional multi-hole probes returning time-averaged flow data. That is, the error associated with the pressure sensor measurement, and the error associated with the probe aerodynamic calibration and pressure-to-velocity reduction process.

The other sources of error are associated with dynamic measurements using fast-response probes. The third source of error is due to the pressure attenuation (or amplification) that results from the need to use tubing to connect the pressures existing at the probe tip to the pressure sensors. Aeroprobe has developed a method to account for this error, which involves calibration of the tubing systems. Please see the section on tubing calibration below for more details.

The second source of error results from flow unsteadiness over a probe tip of finite size. Circulation, vortex shedding, velocity gradients, and flow inertial effects can cause significant errors between the true instantaneous static and total pressure in the flow and those measured by the probe. The most significant deviations from the steady flow result from flow inertial effects. In flowfields with high frequency content, multi-hole probes can be subject to large unsteady flow effects that must be accounted for to accurately predict the instantaneous three-dimensional velocity vector.

This objective of the remainder of this section is to educate the probe user on the magnitude of the expected errors if a hemispherical-tip probe is used in an unsteady flowfield *and no correction for inertial effects is applied*.

For a general, unsteady (not necessarily periodic) flowfield, the non-dimensional acceleration K is the parameter that indicates the expected errors. *The value of the non-dimensional acceleration coefficient is identical to the error in the estimation of the instantaneous dynamic pressure if the inertial effects are ignored*

K is defined as:

$$K = \frac{dU}{dt} \frac{R}{U^2}$$

where

U = Instantaneous Velocity Magnitude

R = Radius of the Probe Tip.

Finally, the effect of unsteady inertial effects on the error in the prediction of the flow angles is much less than its effect on the velocity magnitude. For example, if the flow angles are low relative to the probe axis (pitch and yaw angles in the range between -20° and

20°), the errors made in the estimation of the flow angles, even for K values as high as 0.5, are less than 0.5%.

Example:

Consider a probe with $R = 1$ mm placed in an oscillating air stream at zero incidence angle. The flow is taken to be sinusoidal with a frequency of 2 kHz, with a mean velocity of 60 m/s and 30%

amplitude. For this case, the calculated maximum K (corresponding to the point in the sine wave where dU/dt is a maximum) is 0.075, meaning that a maximum measurement error in the predicted instantaneous dynamic pressure of 7.5% is expected if the unsteady inertial effects are not accounted.

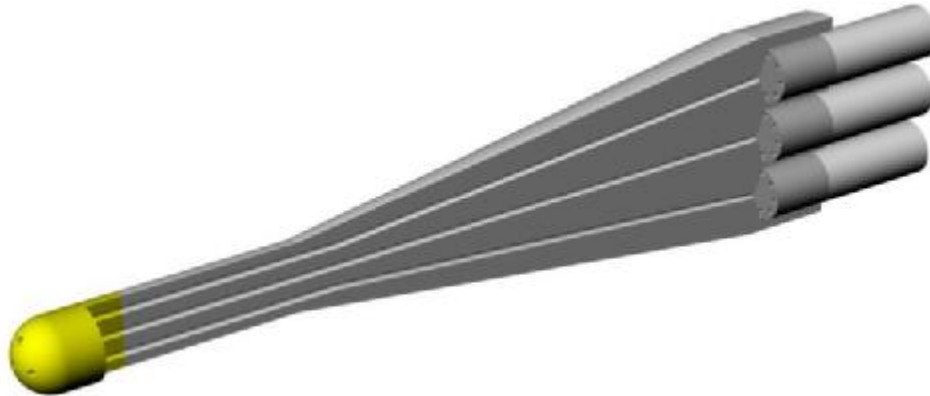

Cross-Sectional View of 5-Hole Probe with Transducers Embedded in the Probe Shaft, Similar to Construction of -ER Model Probes.

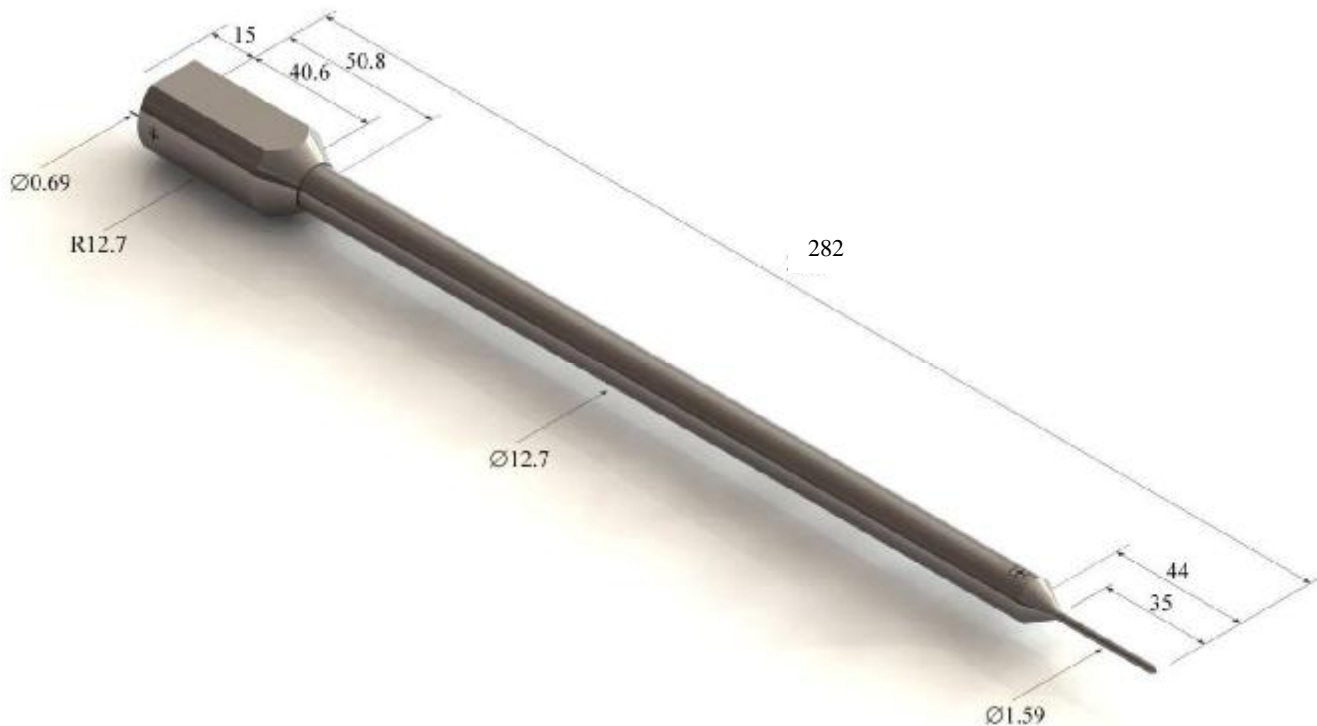

Fast-Response Probe Model FRPS5-SR-C160-290 with 1.6mm Tip (Smallest Available), 1.0 kHz Frequency Response. Geometry is Similar for other Tip Diameters. Dimensions in Millimeters.

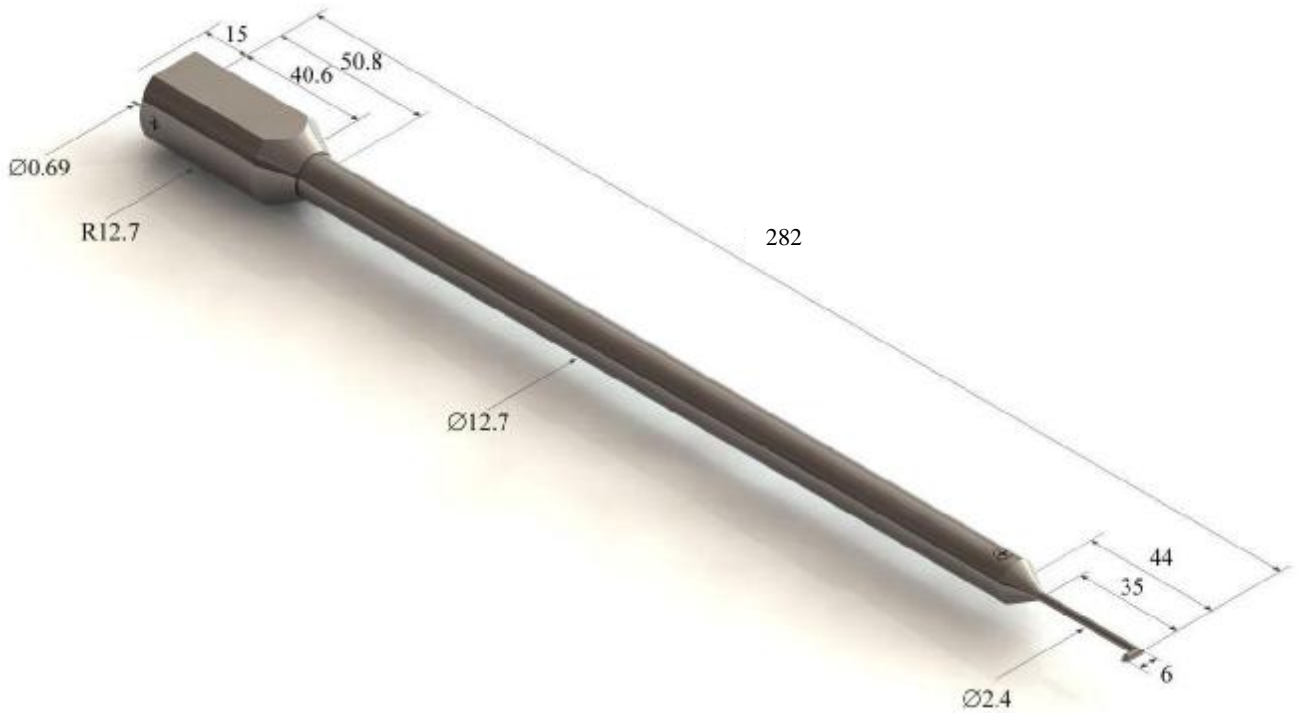

Fast-Response Probe Model FRPL5-SR-C240-290-006 with 2.4mm Tip (Recommended Diameter), 0.8 kHz Frequency Response. Geometry is Similar for other Tip Diameters. Dimensions in Millimeters.

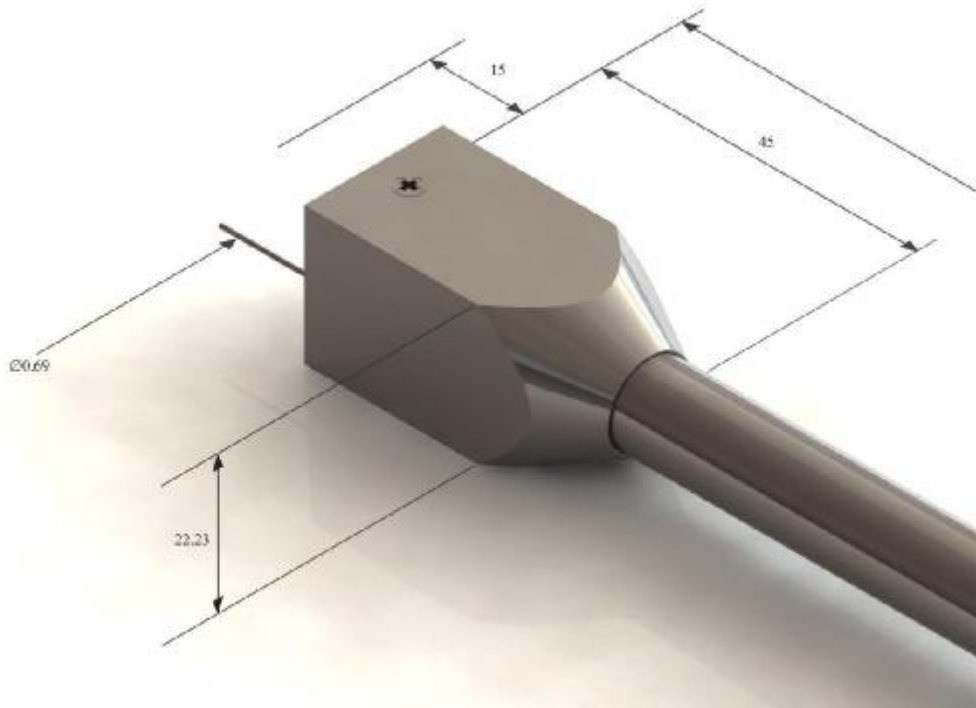

Optional Rectangular Prism Mount for Fast-Response Probes

Calibration of the Fast-Response Probe:

Probe:

Fast-response probes are normally supplied with a full steady calibration, unless this is precluded by geometry restrictions. Additional calibrations at other speeds may be specified on order. In addition, fast-response probes are provided with a calibration for tubing response between the probe tip and sensors.

The probe calibration is essential to proper operation of the probe. It defines a relationship between the measured probe port pressures and the actual velocity vector.

The probe calibration process consists of placing the probe in a uniform, known flowfield (known in terms of velocity magnitude and direction, density, temperature, static pressure), and then rotating the probe to over 2000 different orientations with respect to the known velocity vector. The probe tip is maintained at the same physical location during the entire calibration process. At each orientation, the probe port pressures and the freestream dynamic pressure are recorded. In this way, a calibration map relating pressure and velocity is created.

Facilities:

The three main components of the probe calibration hardware are: the wind-tunnel facility that generates the known flowfield and the probe indexing system, which automatically positions the probe at a series of user-defined orientations and the pressure data-acquisition system. A calibration wind tunnel and probe indexer are shown in the figures below. The indexer is able to rotate the probe through a cone angle (θ) and roll angle (ϕ).

Aeroprobe uses four probe calibration facilities that combined have the ability to accommodate a wide range of probe designs, probe diameters (from 1.6 mm – 76.2 mm), calibration velocities (from 5 m/sec to 320 m/sec) and Mach numbers (0 to 0.95). Calibration speed range restrictions, dependent upon probe diameter, are specified in the table below.

Calibration Speed Restrictions for Various Probe Tip Diameters

Probe Tip Diameter	Calibration Velocity Range
1/16" to 1/4"	5 to 320 m/sec
3/8" to 1"	5 to 60 m/sec

Aeroprobe Corporation

2200 Kraft Drive, Ste 1475

Blacksburg, VA 24060

Ph: 540/443-9215

Fax: 540/443-6525

Web: www.aeroprobe.com

Email: sales@aeroprobe.com

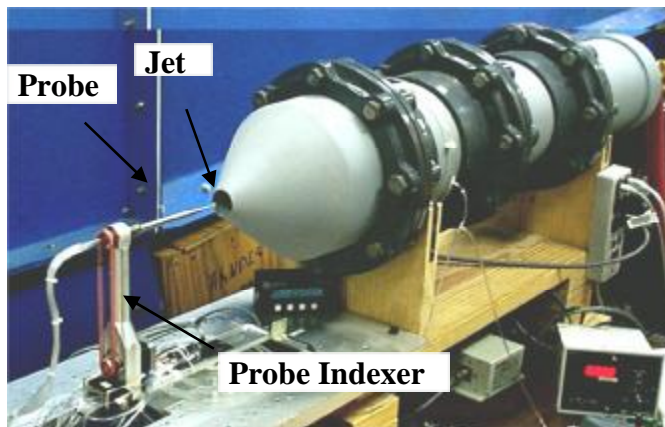

Calibration Facility with Probe Mounted on Indexer

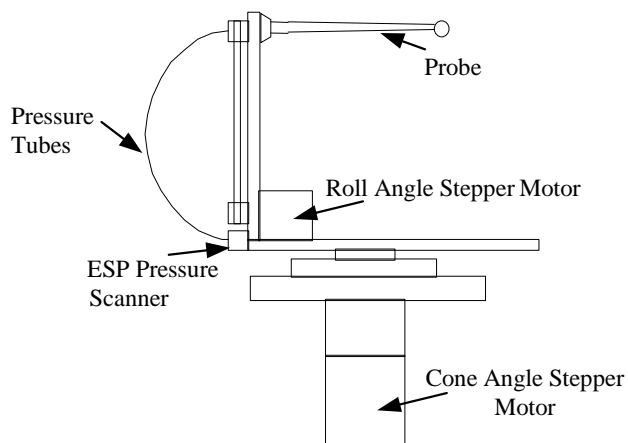
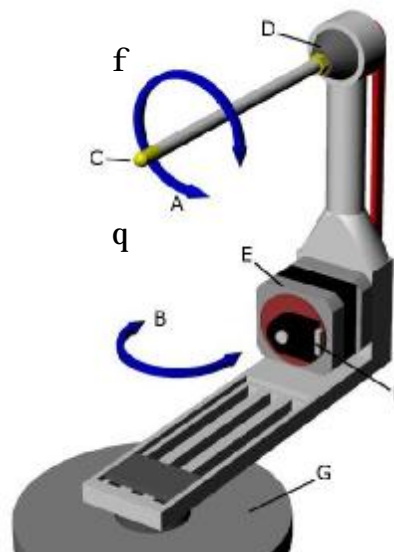

A Typical Probe Indexer Used to Position Probes in the Calibration Facility

Calibration Accuracy:

Pressure data acquisition during probe calibration is performed using different types of differential pressure transducers depending on the required pressure range, which is dictated by the range of velocities at which the probe is to be calibrated. The typical static accuracy of the transducers is 0.1% of the full scale reading. In order to minimize the effect of possible air temperature changes during a calibration, the transducers periodically undergo an automated zero-offset calibration process. The cone (θ) and roll (ϕ) positioning have resolutions of 0.9° , and are both equipped with rotational encoders, resulting in position accuracy on the order of 0.01° .

Multiple Calibrations:

If the user plans to use the probe over a wide range of speeds, Aeroprobe recommends that the probe be calibrated at multiple speeds. This allows our pressure-to-velocity reduction software (Multiprobe) to interpolate between multiple calibration files for increased ease of reduction and data accuracy. A typical calibration velocity schedule across the entire range of calibration facilities is listed in the table below. Calibrations spaced at $\Delta M = 0.1$ or less across the planned test velocity range are recommended.

Typical Freestream Velocity Schedule for Entire Facility Range

Mach Number	Nominal Speed (m/s)
0.015	5 m/s
0.03	10 m/s
0.05	17.3 m/s
0.1	34.5 m/s
0.2	69.0 m/s
0.3	103.5 m/s
0.4	138 m/s
0.5	172.5 m/s
0.6	207 m/s
0.7	241.5 m/s
0.8	276 m/s
0.9	310.5 m/s

Acoustic Calibration of Tubing:

Because of the large uncertainty and tolerances in small diameter tubing systems, and the fact that assumptions necessary for theoretical treatment (such as laminar flow and circular cross-section) may not be satisfied, a calibration system was designed with the ability to accurately determine the frequency response of miniature tubing systems. This calibration system generates a repeatable fluctuating pressure at the inlet of the tubing system, while continuously monitoring the inlet pressure (p_s) and the pressure at the receiving end of the tubing system (p_r).

The loudspeaker is used to generate a sinusoidal pressure signal in the cavity with accurately set frequency and amplitude. Determination of the transfer function of the tubing system necessitates that the frequency be scanned through a range of values. At each separate frequency, the amplitude ratio p_r/p_s is calculated as well as the phase angle between the two signals. The calibration information obtained is used in the pressure-to-velocity reduction routine for fast-response probes to correct for the differences between the actual and measured pressure signals (see section on Multiprobe Reduction Software below).

For larger sensors, it is not always possible to embed the sensors in the probe. In this case, the traditional placement of the sensors outside of the probe is required. However, calibration of a probe and connecting tubing for pressure attenuation and frequency response combined with a reduction technique that uses the acoustic calibration data can still achieve accurate unsteady measurements for substantial bandwidth, depending on the length of tubing required and the characteristics of the sensors.

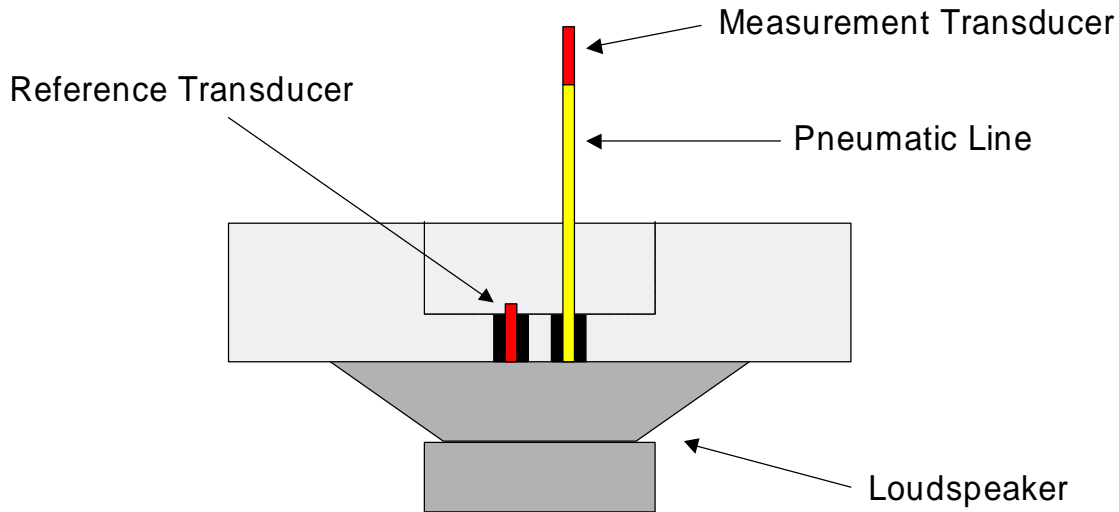

Calibration Facility to Determine the Transfer Function for Tubing Systems. The Signal of the Measurement Transducer is Compared to that of the Reference Transducer. The Relative Time Lag and Ratio of the Amplitudes of these Signals Provides the Acoustic Calibration that is Used with the Fast-Response Probes.

Multiprobe Reduction Software with Acoustic Response Correction:

Multiprobe is a pressure-to-velocity reduction software package that uses the aerodynamic probe calibrations to reduce measure port pressures to velocity information. Multiprobe utilizes a local-least squares (LLS) fit of the closest (to the test point in question) calibration points, for each of the calibration variables. The LLS searching algorithm uses specialized multi-region search routines and angular range validation routines to improve accuracy. Multiprobe has the ability to utilize multiple aero calibrations, interpolating in Mach/Re numbers for more accurate prediction.

ARC (Acoustic Recovery) is an acoustic correction software that corrects for the amplitude changes of the unsteady pressure signals that occurs between the probe tip and the sensors. The ARC software uses the acoustic probe calibrations to perform the correction. Through a method in which FFT and deconvolution are applied, the tubing calibration data

are used to process time-series pressure data in order to recover accurately the actual pressures at the probe tip.

For processing of data from fast-response probes, Multiprobe can integrate the ARC software package. Both software packages are post-processing, Windows-compatible packages. Multiprobe and ARC have GUI front-ends that retrieve user input and then call functions stored in a DLL. Aeroprobe makes these DLL's available to the user for programming custom applications and making pressure-to-velocity reduction and acoustic correction function calls from custom software. Existing current language support includes C/C++, Delphi, Visual Basic, and scripts for Excel.

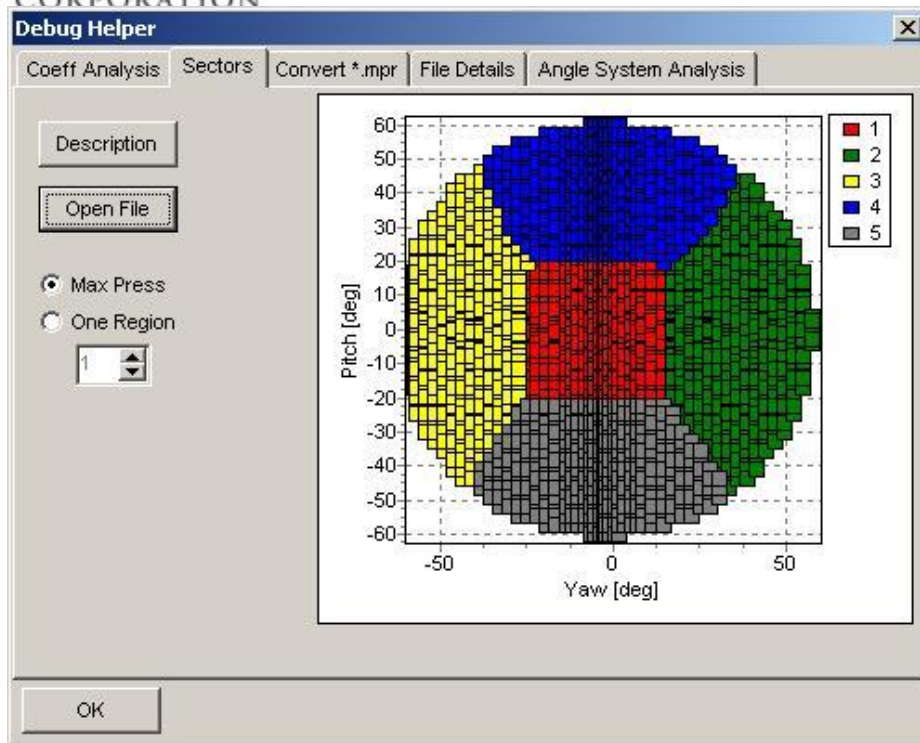

Multiprobe Pressure-to-Velocity Reduction Software

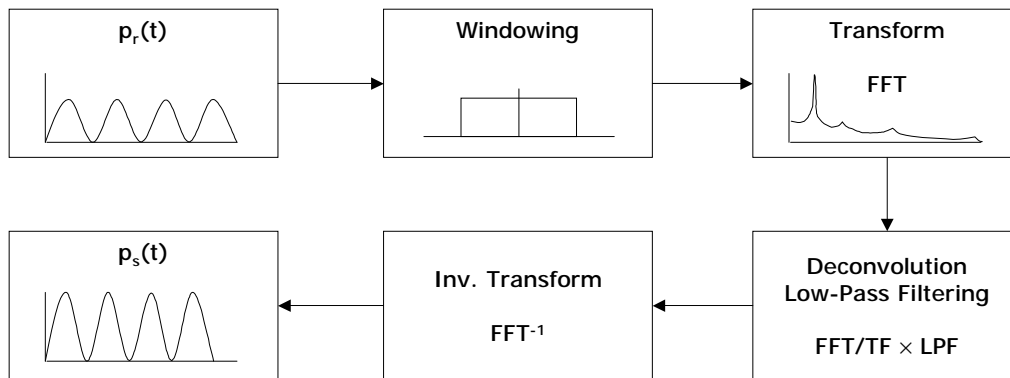

Flowchart for Pressure Signal Reconstruction from the Indicate Signal at the Transducer (P_r) to the Actual Pressure Signal Existing at the Probe Tip (P_s).

Additional Information

Please refer to the conventional multi-hole probe product information sheets for more details about probe geometry, probe calibrations and pressure-to-velocity reduction software for steady flows.

For information about other Aeroprobe products, please visit our website: www.aeroprobe.com.

Aeroprobe Corporation
2200 Kraft Drive, Ste 1475
Blacksburg, VA 24060

Ph: 540/443-9215
Fax: 540/443-6525

Requirements

Multiprobe, AeroAcquire and ARC software requires Windows 2000, XP or 7.

Web: www.aeroprobe.com
Email: sales@aeroprobe.com

Notes:

- Fast-Response Probes Include One Standard Calibration at a Speed of the Customer's Choice (5 m/s – 320 m/s) if Probe Geometry Permits. **Specify Speed on Order!**
- Fast-Response Probes are Supplied with a NIST-Traceable Pressure-Voltage Calibration of the Embedded Sensors



Fast-Response Aeroprobe, AMX4K Data Acquisition Module and Connecting Cable. Interface from Module to PC is USB Cable. Data Acquisition Driven by AeroAcquire, Integrating Multiprobe and ARC Software Packages for Reduction of Time-Accurate Flow Data.



Fast-Response Probe Item Ordering Information

Item	Description
Fast-Response Probes	
FRPL5-ER-160	L-Shaped Five-Hole Fast-Response Probe, Model FRPL5-ER-C160-270-006. 2.0 kHz Resp.; Min. Sensor Range ± 1 psi, Specify Range, Sensor Calibration Included; Aero Calibrated, Specify Speed.
FRPL5-ER-240	L-Shaped Five-Hole Fast-Response Probe, Model FRPL5-ER-C240-270-006. 3.2 kHz Resp.; Min. Sensor Range ± 1 psi, Specify Range, Sensor Calibration Included; Aero Calibrated, Specify Speed.
FRPL5-ER-320	L-Shaped Five-Hole Fast-Response Probe, Model FRPL5-ER-C320-270-006. 4 kHz Resp.; Min. Sensor Range ± 1 psi, Specify Range, Sensor Calibration Included; Aero Calibrated, Specify Speed.
FRPL5-SR-160	Standard L-Shaped Five-Hole Fast-Response Probe, Model FRPL5-SR-C160-290-006. 0.5 kHz Resp.; Min. Sensor Range 10"WC, Specify Range, Sensor Calibration Included; Aero Calibrated, Specify Speed.
FRPL5-SR-240	Standard L-Shaped Five-Hole Fast-Response Probe, Model FRPL5-SR-C240-290-006. 0.8 kHz Resp.; Min. Sensor Range 10"WC, Specify Range, Sensor Calibration Included; Aero Calibrated, Specify Speed.
FRPL5-SR-320	Standard L-Shaped Five-Hole Fast-Response Probe, Model FRPL5-SR-C320-290-006. 1.2 kHz Resp.; Min. Sensor Range 10"WC, Specify Range, Sensor Calibration Included; Aero Calibrated, Specify Speed.
FRPS5-ER-160	Standard Straight Five-Hole Fast-Response Probe, Model FRPS5-ER-C160-270. 2.5 kHz Resp.; Min. Sensor Range ± 1 psi, Specify Range, Sensor Calibration Included; Aero Calibrated, Specify Speed.
FRPS5-ER-240	Standard L-Shaped Five-Hole Fast-Response Probe, Model FRPS5-ER-C240-270. 3.7 kHz Resp.; Min. Sensor Range ± 1 psi, Specify Range, Sensor Calibration Included; Aero Calibrated, Specify Speed.
FRPS5-ER-320	Standard Straight Five-Hole Fast-Response Probe, Model FRPS5-ER-C240-270. 4.5 kHz Resp.; Min. Sensor Range ± 1 psi, Specify Range, Sensor Calibration Included; Aero Calibrated, Specify Speed.
FRPS5-SR-160	Standard Straight Five-Hole Fast-Response Probe, Model FRPS5-SR-C160-290. 0.7 kHz Resp.; Min. Sensor Range 10"WC, Specify Range, Sensor Calibration Included; Aero Calibrated, Specify Speed.
FRPS5-SR-240	Standard Straight Five-Hole Fast-Response Probe, Model FRPS5-SR-C240-290. 1.0 kHz Resp.; Min. Sensor Range 10"WC, Specify Range, Sensor Calibration Included; Aero Calibrated, Specify Speed.
FRPS5-SR-320	Standard Straight Five-Hole Fast-Response Probe, Model FRPS5-SR-C320-290. 1.4 kHz Resp.; Min. Sensor Range 10"WC, Specify Range, Sensor Calibration Included; Aero Calibrated, Specify Speed.
Aeroprobe AMX4K Data Acquisition System Modules and Cables	
AMX4K-5E	Data Acquisition and Sensor Support Module for 5-Hole FR Probe, -ER Model. Provides Regulated Power and Reference Pressure Sensor, Includes 16-Bit Data Acquisition and USB Interface
AMX4K-5S	Data Acquisition and Sensor Support Module for 5-Hole FR Probe, -SR Model. Provides Regulated Power and Reference Pressure Sensor, Includes 16-Bit Data Acquisition and USB Interface
FRCAB5L-10	Standard Fast-Response Probe-to-DAQ Cable (10', 3.05 m), for 5-Hole FR Probe
FRCAB5L-XX	Standard Fast-Response Probe-to-DAQ Cable (XX'), for 5-Hole FR Probe
Modules and Cables for Connection to Other Data Acquisition Systems	
FRCAB5N-10	Standard FR Probe-to-INT Cable, for Connection to FRP-INT Module (10 ft., 3.05m), for 5-Hole FR Probe
FRCAB5L-10F	Standard FR Probe-to-DAQ Cable (10ft., 3.05 m), for 5-Hole FR Probe, Connector to Flying Leads
FRP-INT	Inline Interface Module for -SR Fast-Response Probes. Provides Power/Signal Conditioning and Splitting for Fast-Response Probes. REQUIRED for -SR Probes when Connected to Customer DAQ System.
Calibration Services	
XCS	Extra Standard 5-7 Hole Probe Calibration
SACS	Standard Setup and Acoustic Calibration of One Tubing System
SACS5	Standard Setup and Acoustic Calibration of 5-Hole Fast-Response Probe
Processing and Reduction Software	
SW-MP	Multiprobe Pressure-to-Velocity Reduction Software
WIN-ARC	Acoustic Recovery Software for Unsteady Pressure Signal Reconstruction

Fast-Response Aeroprobe Specifications

GEOMETRY AND CONSTRUCTION		PERFORMANCE (w/Aeroprobe Calibrations: Aero, Acoustic, Sensor)		
Models	SR (Standard Response) ER (Enhanced Response)	Flow Measurement		
Probe Geometry	Straight L-Shaped	Flow Angle Error*	±0.4° typical	
Number of Tip Ports	5, 7	Flow Velocity Error*	±0.8% typical	
Tip Geometry	Standard: 30° Conical, Hemispherical	Required Thermo Data	Reference Pressure, Total Temperature	
Tip Diameter	Standard: 3.2 mm Option: 1.6 mm, 2.4 mm, 6.35 mm	Spatial Resolution	½ Tip Diameter	
Material	Stainless Steel, except for Electronics and Seals	Standard 5-Hole FRP Frequency Response		
Standard Pressure Ranges	SR: ±10"WC; ±1, ±2, ±5, ±15, ±50psi ER: ±1, ±2, ±5, ±15, ±50psi	SR Model	1.6mm Tip	Straight: 0.7 kHz L-Shaped: 0.5 kHz
			2.4mm Tip	Straight: 1.0 kHz L-Shaped: 0.8 kHz
			3.2mm Tip	Straight: 1.4 kHz L-Shaped: 1.2 kHz
Pneumatic Connection	Tygon R3603 Formulation, 1/32" ID, 3/32" OD Standard for Single Reference Exit Tube of 1.07 mm (0.042") OD.	ER Model	1.6mm Tip	Straight: 2.5 kHz L-Shaped: 2.0 kHz
Electrical Connection	LEMO Electronic Connector		2.4mm Tip	Straight: 3.7 kHz L-Shaped: 3.2 kHz
Mounting	Standard: Hex Prism Option: Rectangular Prism, Cylindrical		3.2mm+ Tip	Straight: 4.5 kHz L-Shaped: 4.0 kHz
Probe Reference	Flat on Hex or Rectangular Mount			
ELECTRICAL (Internal Amplification)		OPERATION		
Sensor Accuracy (Bias)	±0.4% FSO or Better, with NIST-Traceable Calibration (Included with Probe Purchase)	Flow Angle of Receptivity	< 60° Total Angle (5HP) < 70° Total Angle (7HP)	
Full-Scale Output	SR: 0-4.5 VDC ER: ±4.5 VDC	Temperature Range	SR (Operating): -25°C to 85°C ER (Compensated) : -18°C to 93° C)	
Supply Voltage	10V Nominal, 18V Maximum	Fluid Temperature Measurement	Tip Thermocouple Option, Compatible with AeroAcquire Data Acquisition Software (2.4+ mm ProbeTips Only)	
Electrical Configuration	Each Sensor – Active Four Arm Piezoresistive Bridge	Sensor Temperature Measurement	Sensor Thermocouple Option for Extended Temperature Sensor Compensation, Compatible with AeroAcquire Data Acquisition Software	
CALIBRATIONS				
Aerodynamic	5 m/s to 320 m/s (Mach = 0.93) Available, Calibration at One Speed Included with Cost of Probe. Used by Multiprobe P-V Reduction Software	*Utilizing 0.4% Accurate Pressure Sensors Properly Rated for Flow Speed		
Acoustic	Sold Separately, Calibration Across Usable Bandwidth, Used by ARC Correction Software	**Data Acquisition Provided By AMX4K FR Probe Data Acquisition Module with AeroAcquire Software (Purchased Separately)		
Sensor	NIST-Traceable Sensor Calibration Included with Probe, Used by AeroAcquire Data Acquisition Software			