

Conventional Multi-Hole Probes

Engineering
Flow-Measurement
Solutions

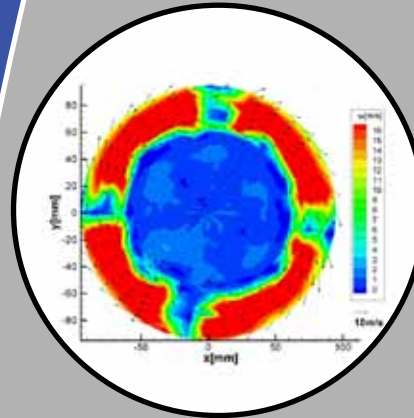
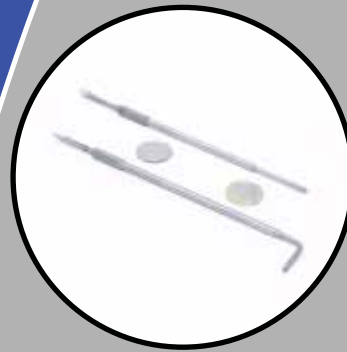

A
E
R
O
P
R
O
B
E

Conventional Multi-Hole Probes

- 5-Hole Probes
- Calibration Services

- 7-Hole Probes
- Multiprobe Reduction Software



Aeroprobe
CORPORATION

Applications:

- Determination of Three Components of Flow Velocity Plus Total and Static Pressure at Probe Tip
- Accurate Resolution of Velocity Vectors as High as 60° (5-Hole) or 70° (7-Hole) from Probe Axis
- Usable in Air and Water Environments
- Flow Speeds from 5 m/s to 325 m/s, Mach 0.02 to Mach 0.95
- Max Frequency Response up to 200 Hz, with Correction, Depending on Pressure Sensors and Pneumatic Connections

Features:

Multi-Hole Probes

- Standard Probe Tip Diameters as Small as 3.2 mm, with 1.6 mm Option
- Multiple Standard Probe Geometries
- Standard Manufacturing Uses Stainless Steel Components for Rugged Construction
- Hemispherical or Conical Probe Tips
- Aeroprobe Expertise in Probe Design and Construction

- Long Probe Calibration Intervals, with Normal Operation

Calibrations

- High-Accuracy, 2000+ Point Calibrations
- Complete Post-Calibration Error Analysis and Quality Control
- Calibrations of Non-Aeroprobe Probes

Multiprobe (Pressure-to-Velocity Reduction Software)

- High Accuracy Reduction with Local-Least Square (LLS) or Sector Fitting
- Max Errors of 0.8% in Velocity Magnitude, 0.4° in Flow Angles
- Multi-Region Searching Algorithm for Boundary Points
- Windows DLL Provided for Integration of Reduction Routines into Custom Software, Allowing Real-Time Data Reduction
- Reduction Interpolation between Calibrations at Multiple Speeds
- Angular-Range Validation of Reduced Data

Introduction:

Multi-hole probes are fluid mechanics instruments designed to measure the flow velocity and pressure through direct measurement of the pressures at the probe tip, and then using the pressures to calculate a velocity. These probes measure flow velocity and pressure by interfering (as little as possible) with the flow in a particular and consistent manner. A one-time calibration of the probe at a known flow speed and angle, followed by processing of the raw pressure data provides a non-dimensional pressure coefficient map to which subsequent measured pressures are non-dimensionalized and compared. In this way, the unknown velocity vector, as well as the total and static pressure at the measurement location may be determined.

There are four basic elements required for flow measurement using a multi-hole probe: (1) The probe itself (2) An accurate probe calibration (3) The means to measure the probe port pressures and (4) Reduction software to convert the measured pressures to velocities based on the calibration map. This document provides a description of Aeroprobe products and services designed to fulfill the requirements (1), (2) and (4) above.

Multi-Hole Probes

Standard Probes:

Aeroprobe offers three standard probe geometries: straight, L-shaped, and cobra. These can be manufactured with either conical or hemispherical tips. Conical tips are typically manufactured with an included angle of 60°. Standard construction material is stainless steel, giving the probes operating capability from -20°C – 450°C. L-shaped and cobra probes are similar in construction, except that the tip of the cobra probe lies on the axis of the shaft.

Standard 5-hole and 7-hole probes have a 3.2mm tip diameter, and a 152.4mm overall length. The standard hex mount is 6.35mm flat-to-flat, and the mount is also available in a rectangular prism. The standard exit tubing for pressure connections is 1.07mm (0.042”) in diameter, 31.75 mm in length. The standard probe geometries are shown in Figure

1. Geometrically similar probes are available for tip diameters of 1. mm, 2.4mm and 6.35mm.

The main difference between the five-hole and seven-hole probes is the angular resolution capability. Seven-hole probes are highly accurate until the velocity vector reaches a total angle of about 70° with respect to the flow. For five-hole probes this angle is about 60°.

All standard probes are supplied with one calibration at a requested speed. Additional calibrations at other speeds may be specified on order. Custom probes are normally supplied with a full calibration, unless this is precluded by geometry restrictions.

Standard Probe Options:

Standard probe options include reduction of probe tip diameter to 1.6mm or 2.4mm tip diameter and inclusion of a thermocouple (for straight and certain L-shaped geometries). L-shaped probes can be fitted with a drilled-elbow tip in order to shorten the tip length. An example of a drilled elbow tip with a thermocouple installed at the elbow is show in Figure 2.

Custom Probes:

Aeroprobe would be happy to consider your requests for custom probes. Each probe is essentially designated by specifying the geometry fields, as shown in Figure 3. Some minor geometry changes from the standard probes (including but not limited to, increased/decreased length, increased tip diameter and increased tip lengths on bent probes) can be accommodated. Typical custom geometry ranges are given in Table 1, and probes with parameters within these ranges will have minimized customization costs. Please note the restrictions on tip length, neck length and bend radii in Tables 2-4. Aeroprobe can custom-manufacture bent probes with very short tip lengths (T) by using a drilled elbow technique, but there is a maximum length for these elbows as given in Table 5.

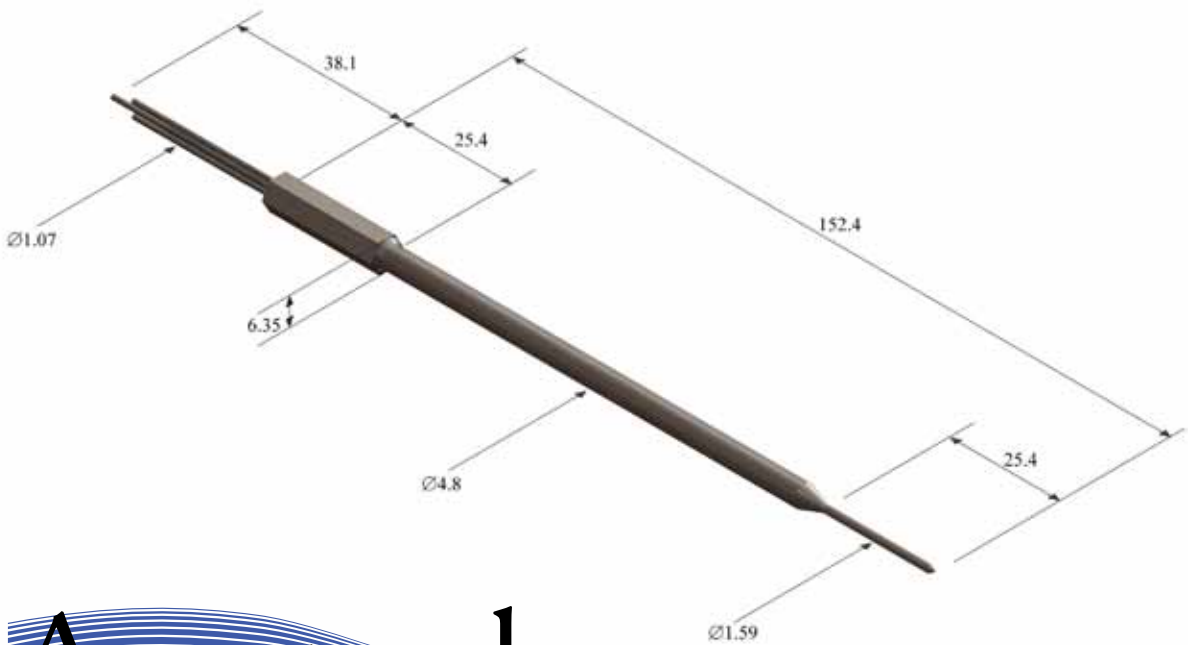
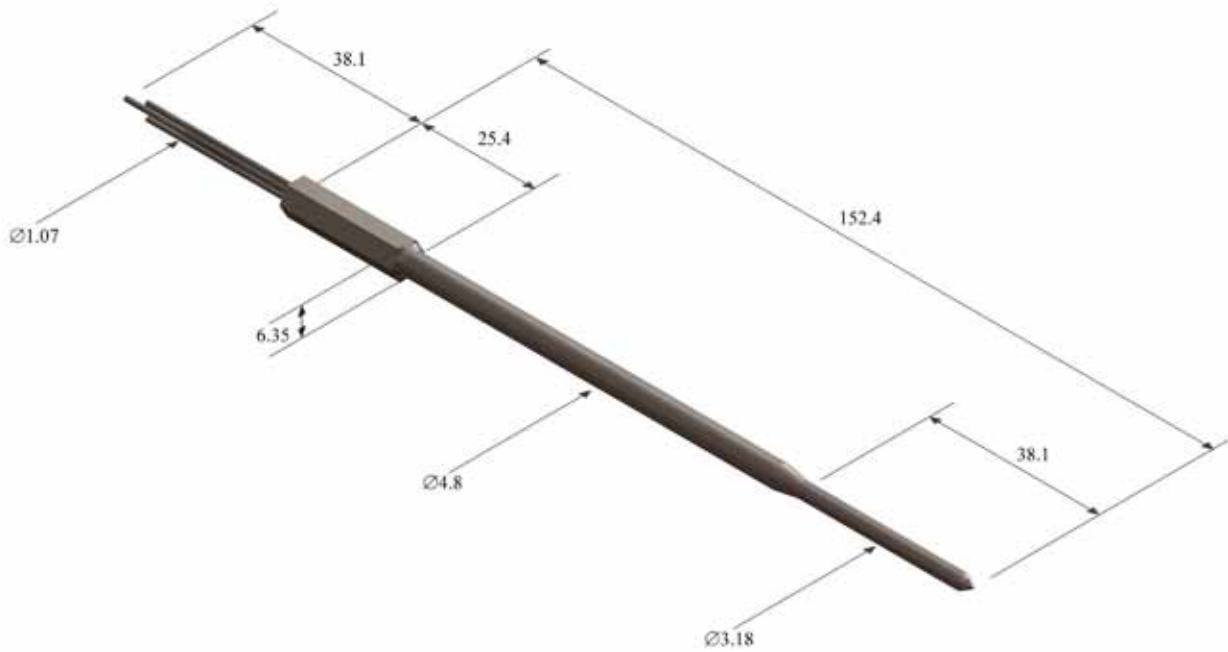

Aeroprobe
CORPORATION

Figure 1(a): Standard Straight Probes with Conical Tips. All Dimensions in Millimeters.

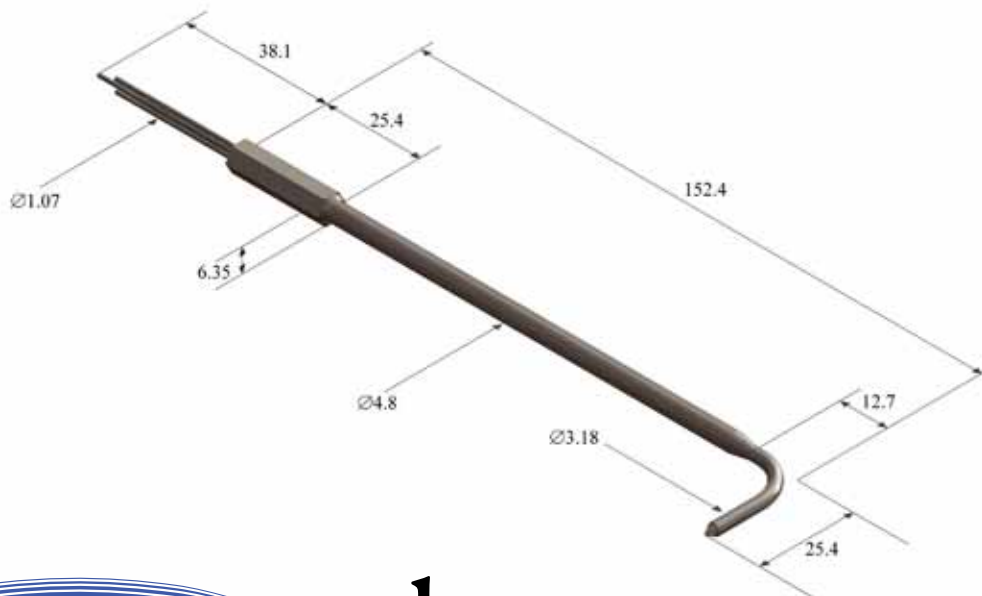
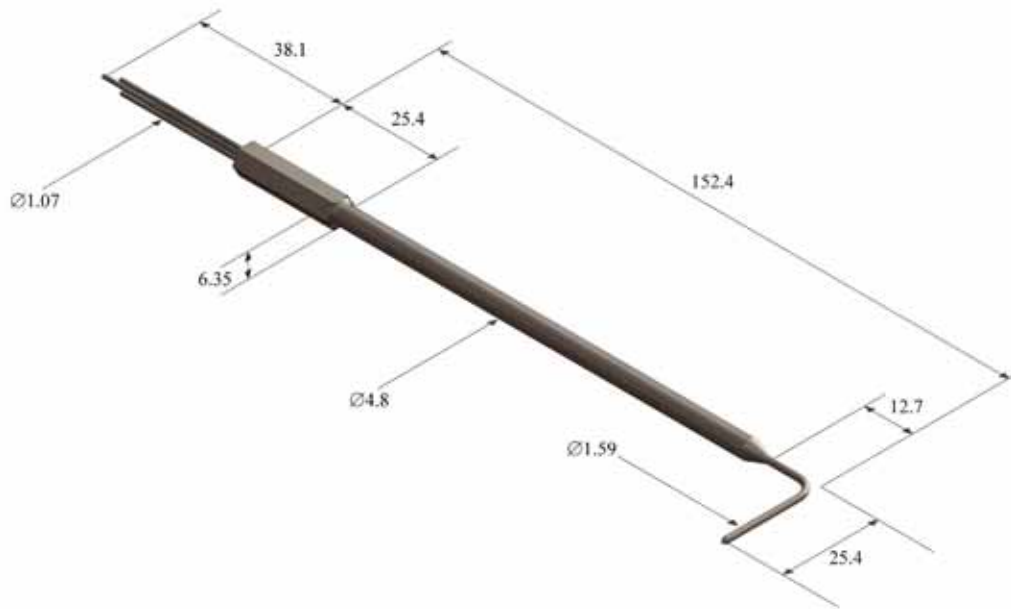

Aeroprobe
CORPORATION

Figure 1(b): Standard L-Shaped Probes with Conical Tips. All Dimensions in Millimeters.

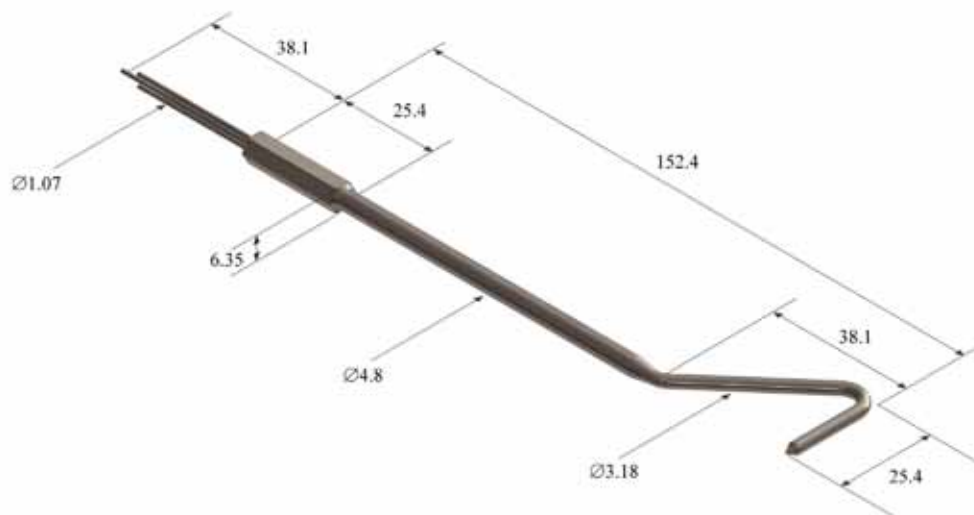
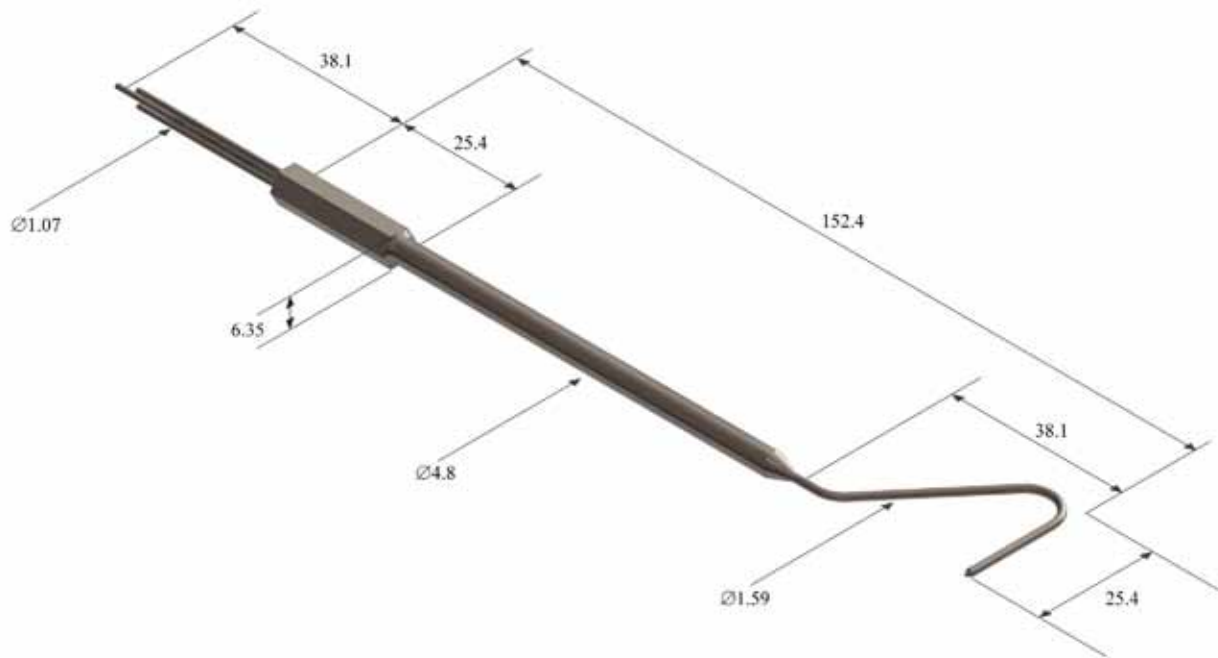

Aeroprobe
CORPORATION

Figure 1(c): Standard Cobra Probes with Conical Tips. All Dimensions in Millimeters.



Aeroprobe
CORPORATION

Figure 2: Example of Drilled Elbow Tip Option with Installed Thermocouple at Elbow.

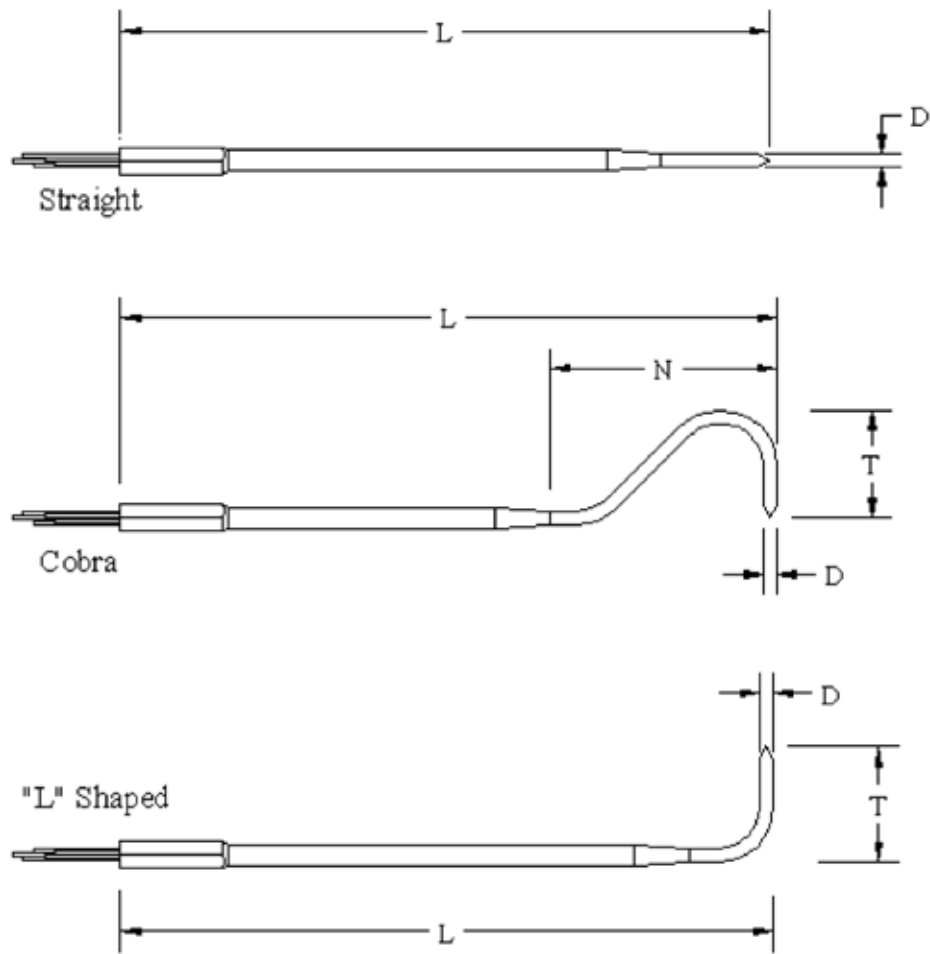

Geometry Code		Model Number Definition											
D	Tip Diameter	P or CP	Probe Type	NP	-	Tip Geom.	D	-	L	-	T	-	N
L	Overall Length												
T	Probe Tip Length												
N	Cobra Neck Length												
Probe Type		P = Standard Probe CP = Custom Probe	Straight, L-Shaped or Cobra See Codes at Left	Number of Probe Ports	-	Conical or Hemispherical See Codes at Left	Tip Diameter in Hundredths of a Millimeter (Three Digits)	-	Overall Length of Probe in Millimeters (Three Digits)	-	Length of Probe Tip in Millimeters (Three Digits)	-	Length of Cobra Neck in Millimeters (Three Digits)
S	Straight												
L	L-Shaped												
C	Cobra												
Tip Geometry		P = Standard Probe CP = Custom Probe	Straight, L-Shaped or Cobra See Codes at Left	Number of Probe Ports	-	Conical or Hemispherical See Codes at Left	Tip Diameter in Hundredths of a Millimeter (Three Digits)	-	Overall Length of Probe in Millimeters (Three Digits)	-	Length of Probe Tip in Millimeters (Three Digits)	-	Length of Cobra Neck in Millimeters (Three Digits)
C	Conical												
H	Hemispherical												
<i>Note: T and N are Used only if Required, Omitted Otherwise</i>													

Figure 3: Probe Design and Specification

Examples:

PL7-C318-152-025 specifies a standard L-shaped seven-hole probe with a conical tip, a 3.18 mm tip diameter, 152 mm overall length and a 25 mm tip length.

CPC5-H159-225-030-050 specifies a custom cobra five-hole probe with a hemispherical tip, a 1.59 mm tip diameter, 225 mm overall length, a 30 mm tip length, and a 50 mm neck length. The standard probe option for the 1.59 mm tip would need to be specified on order.

CPS7-C635-500 specifies a custom straight seven-hole probe with a conical tip, a 6.35 mm tip diameter and 500 mm overall length.

Table 1: Typical Geometry Variations for Custom Probes¹:

Dimension or Component	Minimum	Maximum
Tip Diameter (D)	1.0 mm	8 mm
Overall Length (L)	102 mm	255 mm
Tip Length (T) ²	T _{Min}	102 mm
Neck Length (N) ²	N _{Min}	102 mm
Included Tip Angle (Conical)	40°	60°

¹ Probes complying with these geometry ranges will have minimized customization costs.

² Minimum tip lengths and neck lengths are centerline measurements, and are given in Tables 3 and 4, respectively.

Table 2: Minimum Bend Radii (Centerline)

Component Diameter (mm)	Minimum Bend Radius (mm)
1.59	4.8
3.18	11.0
6.35	15.9

Table 3: Minimum Bent Tip Lengths, T_{Min}, Measured Tip to Shaft Centerline (Cobra and L-Shaped)¹:

Tip Diameter (mm)	Minimum Tip Length (mm)
1.59	14.5
3.18	20.4
6.35	22.3

¹ Shorter tip lengths may be achieved by adding the optional drilled-elbow tip (see Table 5). There is an added cost associated with the drilled elbow option.

Table 4: Minimum Bent Neck Lengths, N_{Min} (Cobra):

Tip Diameter (mm)	Minimum Neck Length (mm)
1.59	16.0 ¹
3.18	34.0
6.35	51.0

¹ During calibration, total angle may be restricted for N < 25 mm.

Table 5: Minimum, Standard and Maximum Drilled Elbow Tip Lengths, Measured Tip to Shaft Centerline (Cobra and L-Shaped):

Tip Diameter (mm)	Min. Tip Length (mm)	Std. Tip Lengths (mm)	Max. Tip Length (mm)
1.59	3.0	4.5 and 6	7.5
3.18	6.0	10	12.0
6.35	9.4	N/A	22.0

Table 6: Standard Tolerances 1:

Dimension or Component	Tolerance
Tip Diameter and Exit Tubes	±0.05 mm
Other Diameters (Housing Tubes):	±0.1 mm
Locations (Centerlines, Ports):	±0.0508 mm, worst case
Primary Lengths	
Primary Lengths (Overall Length, Exit Tubes, Hex Mount, Ferrules):	±2.54 mm
Other Lengths (Bent Leg, Housing Stages)	±5.1 mm
Included Tip Angle (Conical):	±0.5°
On-Axis Bend Angle:	±1°
Off-Axis Bend Angle:	±5°

¹ Tighter tolerances may be specified on order of custom probes



Figure 4: Conventional 3.2mm Probe Tips

Calibration Services

The probe calibration is essential to proper operation of the probe. It defines a relationship between the measured probe port pressures and the actual velocity vector.

The probe calibration process consists of placing the probe in a uniform, known flowfield (known in terms of velocity magnitude and direction, density, temperature, static pressure), and then rotating the probe to over 2000 different orientations with respect to the known velocity vector. The probe tip is maintained at the same physical location during the entire calibration process. At each orientation, the probe port pressures and the freestream dynamic pressure are recorded. In this way, a calibration map relating pressure and velocity is created.

Facilities:

The three main components of the probe calibration hardware are: the wind-tunnel facility that generates the known flowfield and the probe indexing system, which automatically positions the probe at a series of user-defined orientations and the pressure data-acquisition system. A calibration wind tunnel and probe indexer are shown in Figures 4 and 5, respectively. Figure 5 shows how the indexer is able to rotate the probe through a cone angle (θ) and roll angle (ϕ).

Aeroprobe uses four probe calibration facilities that combined have the ability to accommodate a wide range of probe designs, probe diameters (from 1.6 mm - 25.4 mm) and calibration Mach numbers (0.015 to 3.0). Calibration speed/Mach range restrictions, dependent upon probe diameter, are specified in Table 7.

Table 7: Calibration Mach Restrictions for Various Probe Tip Diameters

Probe Tip Diameter	Calibration Mach Range
1/16" to 1/4"	M = 0.015 – 3.0
3/8" to 1"	M = 0.015 – 0.2 (5-70 m/s)

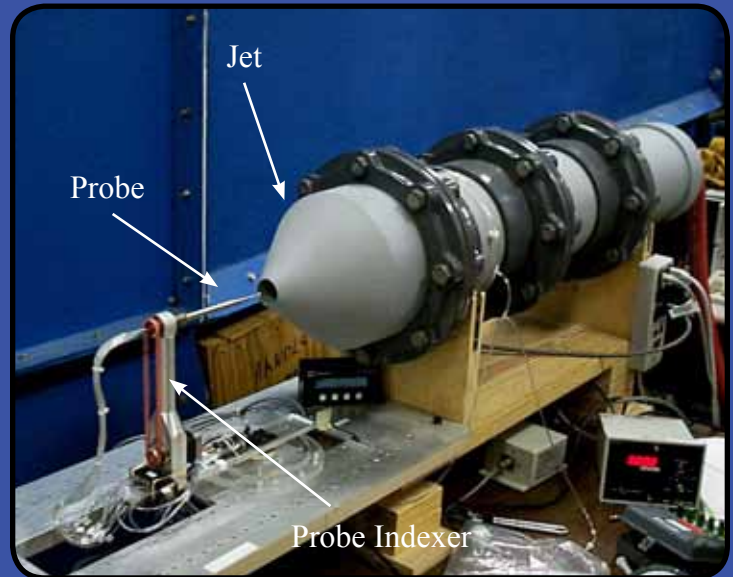

Figure 5: Typical Calibration Facility with Probe Mounted on Dual-Angle Indexer

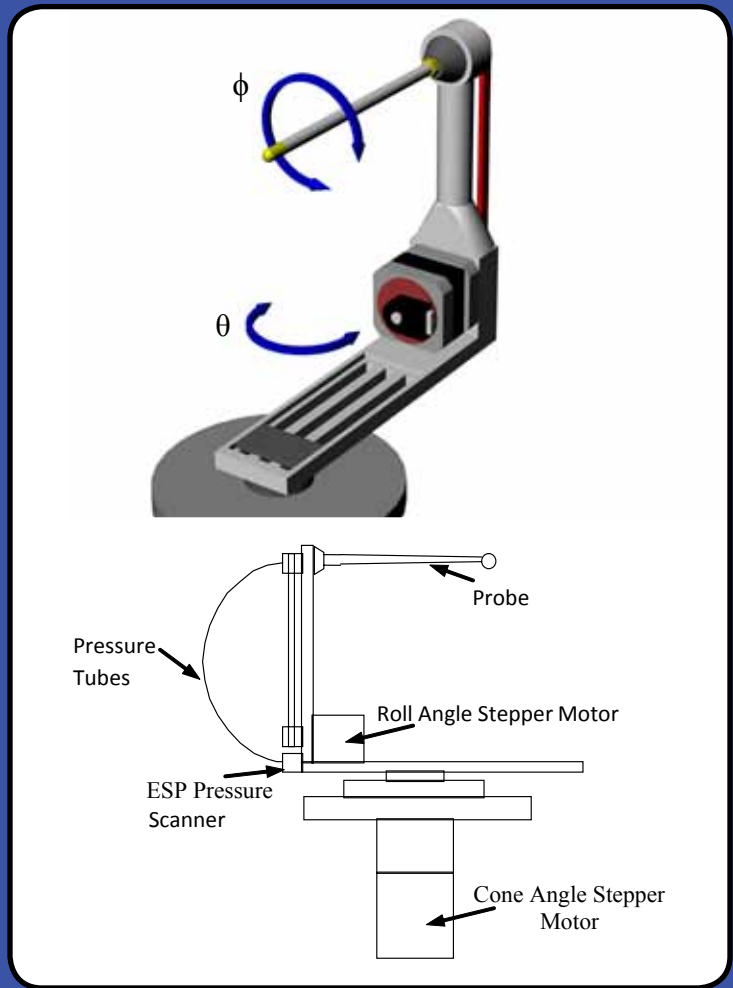

Figure 6: A Typical Probe Indexer Used to Position Probes in the Calibration Facility

Accuracy:

Pressure data acquisition during probe calibration is performed using different types of differential pressure transducers with NIST-traceable calibrations. The transducer range is selected to correspond closely with the dynamic pressure of the calibration, which is dictated by the velocity/Mach at which the probe is to be calibrated. The static uncertainty of the transducers is at most $\pm 0.05\%$ of the full scale reading. In order to minimize the effect of possible air temperature changes during a calibration, the transducers periodically undergo an automated zero-offset calibration process. The cone (θ) and roll (ϕ) positioning have resolutions of 0.03° , and are both equipped with rotational encoders, resulting in position accuracy on the order of 0.06° .

Table 8: Typical Freestream Velocity Schedule for Entire Facility Range

Mach Number	Nominal Speed (m/s)
0.016	5 m/s
0.032	10 m/s
0.05	15.75 m/s
0.1	31.5 m/s
0.2	63.0 m/s
0.3	94.5 m/s
0.4	126 m/s
0.5	157.5 m/s
0.6	189 m/s
0.7	221 m/s
0.8	252 m/s
0.9	284 m/s
1.0	315 m/s
1.1	345 m/s
1.2	365 m/s
1.3	385 m/s
1.4	405 m/s
1.5	430 m/s
1.75	475 m/s
2.0	500 m/s
2.5	580 m/s
3.0	625 m/s

Multiple Calibrations:

If the user plans to use the probe over a wide range of speeds, Aeroprobe recommends that the probe be calibrated at multiple speeds. This allows our pressure-to-velocity reduction software (Multiprobe) to interpolate between multiple calibration files for increased ease of reduction and data accuracy. A typical calibration velocity schedule across the entire range of calibration facilities is listed in Table 8. Calibrations spaced at $\Delta M = 0.1$ or less across the planned test velocity range are recommended.

Non-Aeroprobe Probes:

Our flexibility with probe calibrations allows Aeroprobe to accurately calibrate many different probe geometries, including Pitot-probes and multi-hole probes made by other manufacturers. If the probe design allows, the resulting calibration data can be used in conjunction with Multiprobe to improve accuracy and/or range of the reduced data.

Multiprobe Reduction Software

Multiprobe is the Aeroprobe pressure-to-velocity reduction software package. The basic software is a post-processing, Windows-compatible package. Some Multiprobe windows are shown in Figure 6.

Multiprobe normally utilizes a local-least squares (LLS) fit of the closest (to the test point in question) calibration points, for each of the calibration variables. The LLS searching algorithm uses specialized multi-region search routines and angular range validation routines to improve accuracy. Multiprobe has common file formats with AeroAcquire, Aeroprobe's multi-hole probe pressure data acquisition software package. AeroAcquire automatically integrates Multiprobe for a seamless data acquisition-to-reduction interface, with the ability to provide data real-time to the user.

Multiprobe is a GUI front-end that retrieves user input and then calls functions stored in a DLL. This DLL is available to the user for programming customer applications and making pressure-to-velocity reduction calls from custom software. Integration support for C/C++, Delphi, Visual Basic, MatLab, LabView and Excel are included.

Multiprobe LLS reduction algorithms have typical average errors of 0.8% (or less) in the velocity magnitude and 0.4° (or less) in the flow angles, when used with calibration data generated in our facilities. In addition, the reduction algorithms have the ability to interpolate between multiple calibration files. This gives the user the ability to use the probe over a wide range of speeds while maintaining the reduction accuracy and ease of use normally associated with the use of one calibration file.

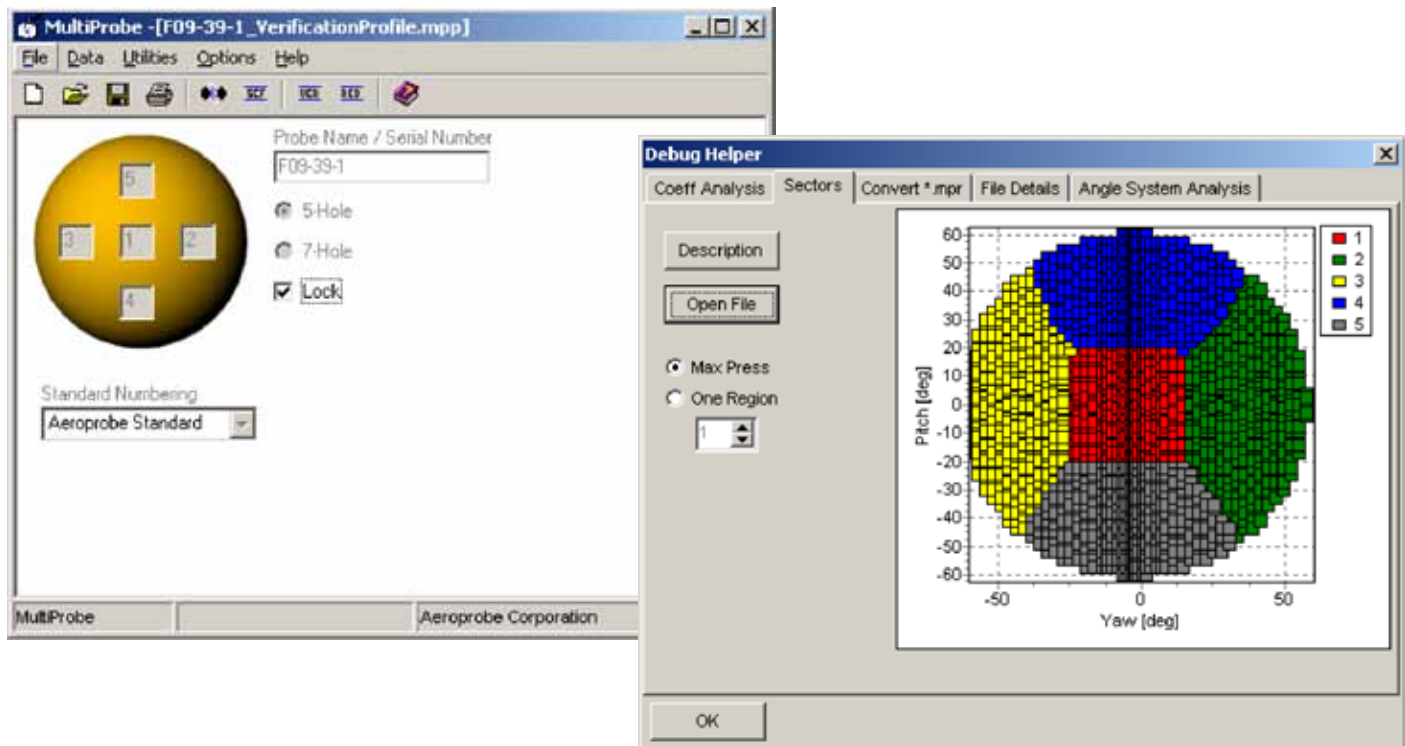

Figure 7: Multiprobe Screen Captures

Ordering Information:

Item	Description
Standard Probes	
PS5	Standard Straight Five-Hole Probe, Calibrated
PL5	Standard L-Shaped Five-Hole Probe, Calibrated
PC5	Standard Cobra Five-Hole Probe, Calibrated
PS7	Standard Straight Seven-Hole Probe, Calibrated
PL7	Standard L-Shaped Seven-Hole Probe, Calibrated
PC7	Standard Cobra Seven-Hole Probe, Calibrated
Standard Probe Options	
TIP-1-1	1.6 mm Tip Diameter for Pitot Probe Tips
TIP-1-3	1.6 mm Tip Diameter for 3-Hole Probe Tips
TIP-1-5	1.6 mm Tip Diameter for 5-Hole Probe Tips
TIP-1-7	1.6 mm Tip Diameter for 7-Hole Probe Tips
TIP-2-1	2.4 mm Tip Diameter for Pitot Probe Tips
TIP-2-3	2.4 mm Tip Diameter for 3-Hole Probe Tips
TIP-2-5	2.4 mm Tip Diameter for 5-Hole Probe Tips
TIP-2-7	2.4 mm Tip Diameter for 7-Hole Probe Tips
TIP-DL1	Drilled Elbow L-Shaped Probe Tip, 1.6 mm Diameter
TIP-DL2	Drilled Elbow L-Shaped Probe Tip, 2.4 mm Diameter
TIP-DL3	Drilled Elbow L-Shaped Probe Tip, 3.2+ mm Diameter
PTC-1	Thermocouple Option for Probes (Probe Tip Diam. 1.6 mm)
PTC-2	Thermocouple Option for Probes (Probe Tip Diam. 2.4 mm)
PTC-3	Thermocouple Option for Probes (Probe Tip Diam. 3.2+ mm)
Repair	
RPRP-CONV-B	Probe Repair, Base
RPRP-CONV-E	Probe Repair, Extended

Item	Description
Pressure-to-Velocity Reduction Software	
SW-MP	Multiprobe Pressure-to-Velocity Reduction Software
SW-MP-UP	Multiprobe Upgrade
Probe Aero Calibrations	
SPCPS	Standard Setup and Calibration of Pitot-Static Probe
SPCPS-SS	Standard Setup and Calibration of Pitot-Static Probe, Supersonic
SPCS	Standard Setup and Calibration of 5/7-Hole Probe
SPCS-SS	Standard Setup and Calibration of 5/7-Hole Probe in Supersonic Facility
SPTC	Standard Setup and Aerodynamic Calibration of Probe TC to Total Temp, with Extra Probe Cal
XCPS	Extra Calibration, Pitot-Static Probe
XCPS-SS	Extra Calibration, Pitot-Static Probe, Supersonic
XCS	Extra Standard 5-7 Hole Probe Calibration
XCS-SS	Extra Standard 5-7 Hole Probe Calibration, Supersonic Facility
XTC	Extra Aerodynamic Calibration of Probe Thermocouple to Total Temp, with Extra Probe Cal
Custom Probes	
CPS5	Custom Straight Five-Hole Probe, Calibrated
CPL5	Custom L-Shaped Five-Hole Probe, Calibrated
CPC5	Custom Cobra Five-Hole Probe, Calibrated
CPS7	Custom Straight Seven-Hole Probe, Calibrated
CPL7	Custom L-Shaped Seven-Hole Probe, Calibrated
CPC7	Custom Cobra Seven-Hole Probe, Calibrated

Requirements:

Use of Aeroprobes requires ability to measure port pressures. Aeroprobe provides complete data acquisition systems and software for this purpose. Multiprobe software requires Windows 2000, XP, Vista or Windows 7.

Notes:

- Standard Probes Are Shown in Figure 1, All Other Geometries Must Be Given a Custom Designation.
- All Standard Probes Include One Standard Calibration at a Speed of the Customer's Choice (5 m/s – M = 3.0). Specify Speed on Order!

- Custom Probes Include One Standard Calibration at a Speed of the Customer's Choice if Probe Geometry Permits. Specify Speed on Order!

Additional Information:

For information about other Aeroprobe products, please visit our websites: www.aeroprobe.com.

Conventional Multi-Hole Aeroprobe Specifications

Geometry and Construction		Measurement Accuracy (w/Aeroprobe Calibration)	
Probe Geometry	Straight, L-Shaped, Cobra	Flow Angles	< 0.4°
Number of Holes	5, 7	Total Flow Velocity	< 0.8%*
Tip Geometry	60° Conical, Hemispherical, 40° Conical Optional	Required Thermodynamic Data**	Reference Pressure, Total Temperature
Tip Diameter	3.2 mm (Standard); 1.6 mm, 2.4 mm, 6.35 mm Optional		
Material	304 Stainless Construction, Including Shafts and Internal Tubing	Flow Cone Angle of Receptivity	60° (5HP), 70° (7HP) NOTE: This is not directly related to the conical angle of the tip!
Pneumatic Connection	Tygon R3603 Formulation, 1/32" ID, 3/32" OD Standard for Exit Tubing of 0.89 mm – 1.6 mm (0.035" – 0.063") OD.	Calibration Flow Speeds	5 m/s to 625 m/s (Mach = 3.0)
		Pressure Data Reduction	Polynomial Fit (3HP), Multiprobe Software (5HP,7HP)
Mounting	Hex Prism (Standard), Rectangular Prism, Cylindrical with Flat	Frequency Response	Low, Best for Determining Time-Averaged Flows, Frequency Calibration Available Upon Request
Probe Reference	Flat on Hex Mount	Media	Non-Reactive Gases Compatible with Stainless Steel, Water (Stainless, 6.35 mm Tip OD Recommended); Other Media Possible – Contact Aeroprobe
Flow Temp. Limits	0°C – 500°C; Wider Limit Options Available	Temperature Measurement	Tip Thermocouple Option, Compatible with AeroAcquire Data Acquisition Software
		*Utilizing 0.1% Accurate Pressure Sensors Properly Rated for Flow Speed	
		**For Most Accurate Compressible P-V Reduction	

Aeroprobe Mission:

Design, develop, manufacture, and deliver 21st -century technology air/liquid flow measurement probes characterized by miniaturization, high accuracy & fast response.

More About Aeroprobe:

A Virginia Tech spin-off, Aeroprobe Corporation is located in the VT Corporate Research Center. Maintaining close ties with VT enables Aeroprobe to perform basic and applied research aimed at advancing probe technology.

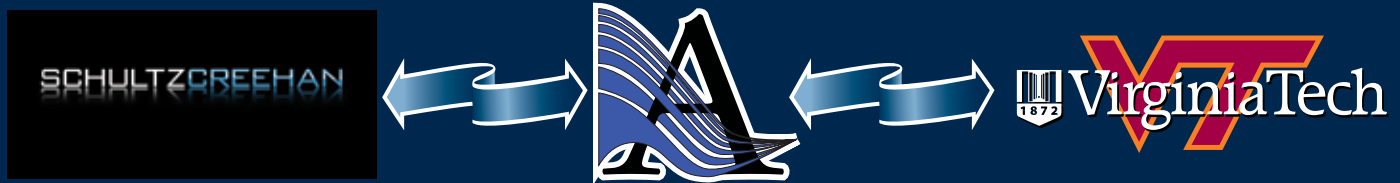

Aeroprobe works closely with manufacturing partner Schultz-Creehan to design, test, and produce high-quality, custom-built measurement devices and equipment employing modular lean-manufacturing methods. Schultz-Creehan has unique mechanical and electronic design, test, and simulation capabilities, which are applied to meet specific customer needs.

Aeroprobe Customers:

- Boeing
- Lockheed Martin
- BMW
- NASA LaRC
- GE Aircraft Engines
- NASA Ames
- GE Energy
- Sandia National Laboratory
- GE R&D
- Texas A&M
- Hill AFB
- Virginia Tech
- Honda R&D

International Business:

With distributors in 20 countries and approximately 50% of sales outside the USA, Aeroprobe is an internationally recognized name.

We have distributors in the following countries:

-
- A globe is shown in the background, with a grid of latitude and longitude lines. The globe is colored in shades of green and blue, representing the Earth. The names of the countries listed are overlaid on the globe, indicating their geographical locations.
- Argentina
 - Australia
 - Austria
 - Belgium
 - Brazil
 - Czech Republic
 - Finland
 - France
 - Germany
 - India
 - Italy
 - Japan
 - Korea
 - Mexico
 - Netherlands
 - Norway
 - Portugal
 - Singapore
 - Slovakia
 - Spain
 - Sweden
 - Switzerland
 - Turkey
 - U.K.

Aeroprobe Corporation
1700 Kraft Dr.
Suite 2350
Blacksburg, VA 24060



Ph: (540) 951-3858
Fax: (540) 951-8618
info@aeroprobe.com
www.aeroprobe.com