

FAST-RESPONSE MULTI-HOLE PROBES

(Patent Pending)

- EMBEDDED SENSORS
- HIGH FREQUENCY RESPONSE
- ACOUSTIC CORRECTION ALGORITHM

APPLICATIONS:

- Determination of Three Components of Unsteady Flow Velocity and Total and Static Pressure at Probe Tip
- Max Frequency Response up to 5 kHz, Depending on Pressure Sensors and Probe Design
- Accurate Resolution of Velocity Vectors as High as 60° (5-Hole) or 70° (7-Hole) from Probe Axis
- Probe Designs and Sensors for Use in Air and Water Environments
- Flow Speeds from 5 m/s to 325 m/s, Mach 0.02 to Mach 0.95

FEATURES:

- **All Standard Multi-Hole Probe Features Plus:**
- Pressure Sensors Embedded in the Probe for Increased Frequency Response
- Calibration of Probe Internal Pneumatic System to Determine Acoustic Response
- Correction Algorithm for Tubing Response and Inertial Effects in Unsteady Flows, for use with Multiprobe

INTRODUCTION:

In dynamically changing flowfields, high-frequency-response flow diagnostics instrumentation is necessary. Until recently, no instrument was available that could provide simultaneous information on the three instantaneous components of velocity and the static and total pressure at a measurement point, in dynamically changing flows. Aeroprobe's fast-response probe technology makes this possible. Fast-response probes are manufactured by embedding the pressure transducers within the multi-hole probe body, greatly increasing the frequency response of the probe.

There are five basic elements required for accurate flow measurement using a fast-response multi-hole

probe: (1) The probe itself (2) An accurate probe calibration in steady flow (3) The means to measure the probe port pressures and (4) Processing software to correctly account for the effects of unsteady flow on the measured pressures, so that the actual tip pressures can be recovered from the measured data and (5) Reduction software to convert the actual pressures to velocities based on the calibration map. This document provides a description of Aeroprobe products and services that fulfill requirements (1), (2), (4) and (5) above.

FAST-RESPONSE PROBES:

Because of the complexity of fast-response probes and because the design is often very closely tied to the application, Aeroprobe manufactures all fast-response probes to order, and does not currently have a standard fast-response probe. Designs that are similar to our standard multi-hole probes are common, with slight modifications to embed the sensors.

All fast response probes must be either five-hole or seven-hole models. Aeroprobe offers two basic fast-response probe geometries: straight and L-shaped. These can be manufactured with either conical or hemispherical tips. Conical tips are typically manufactured with an included angle of 60°. Standard construction materials are a combination of brass and stainless steel, but all-stainless construction is possible. Fast-response probes can be manufactured with tip diameters from 1.59 mm (available in brass only) to 12.7 mm. Because small tip diameters limit the errors due to tip inertial effects in unsteady flow (see Estimation of Accuracy section below), Aeroprobe recommends using as small a tip diameter as applications permit.

Fast-response probes are normally supplied with a full steady calibration, unless this is precluded by geometry restrictions. Additional calibrations at other speeds may be specified on order. In addition, fast-response probes are provided with a calibration for tubing response between the probe tip and sensors.

Fast-Response Probe Design:

The design of a fast-response probe is dictated by several factors: (1) Desired frequency response (2) Required pressure range (both static and dynamic) at which the probe will operate and (3) Desired probe geometry. The selection of sensors is greatly influenced by these factors, and this is the most important part of the probe design process.

Sensors may be embedded in the probe at several different locations, depending on probe size and geometry. For larger probe tips and small sensors, it may be possible to place the sensors very near the tip, giving the best frequency response. However, due to

geometry restrictions, it is sometimes more reasonable to place the sensors in the probe shaft.

For large sensors (typically for pressure ranges < 1 psi full scale), it is not always possible to embed the sensors in the probe. In this case, the traditional placement of the sensors outside of the probe is required. However, calibration of the probe and connecting tubing for pressure attenuation and frequency response combined with a reduction technique that uses the calibration data can still achieve accurate unsteady measurements as high as 1 kHz, depending on the length of tubing required and the characteristics of the sensors.



Five-Hole Embedded Sensor Probe for GE Aircraft Engines. Five Pressure Sensors are Contained in the Bullet-Shaped Tip

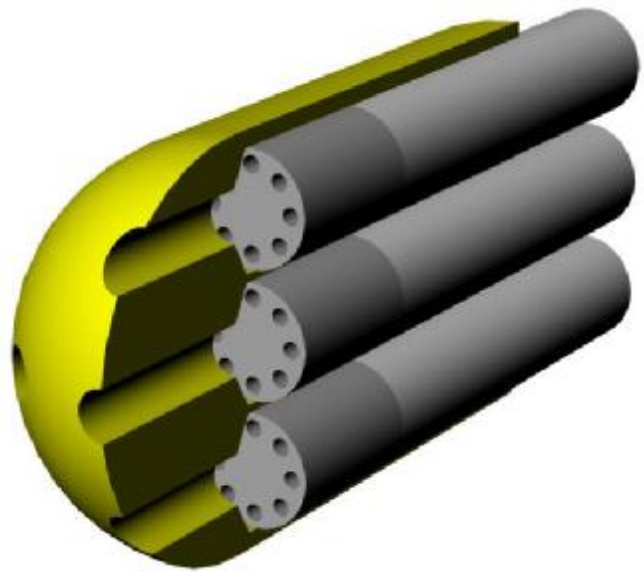

Cross-Sectional View of a Fast-Response Probe with Pressure Transducers Embedded in the Tip.

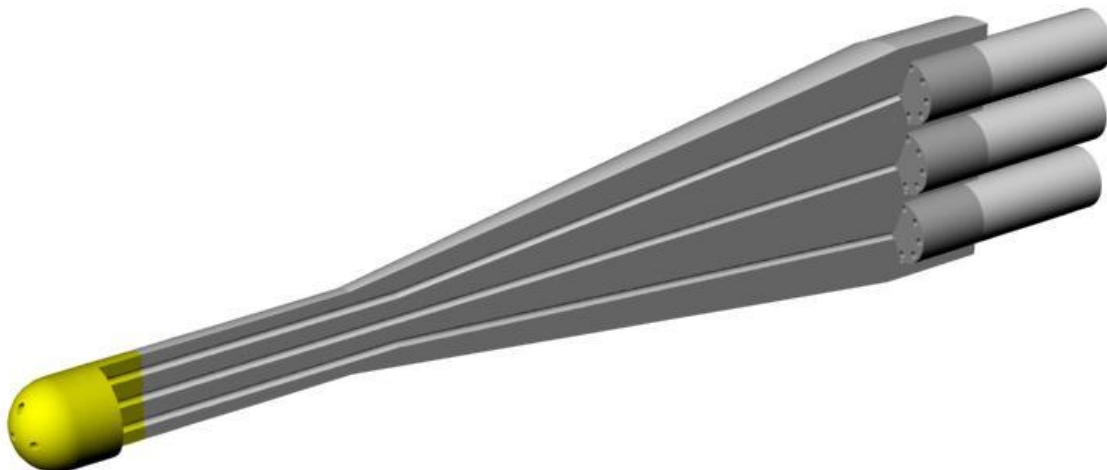

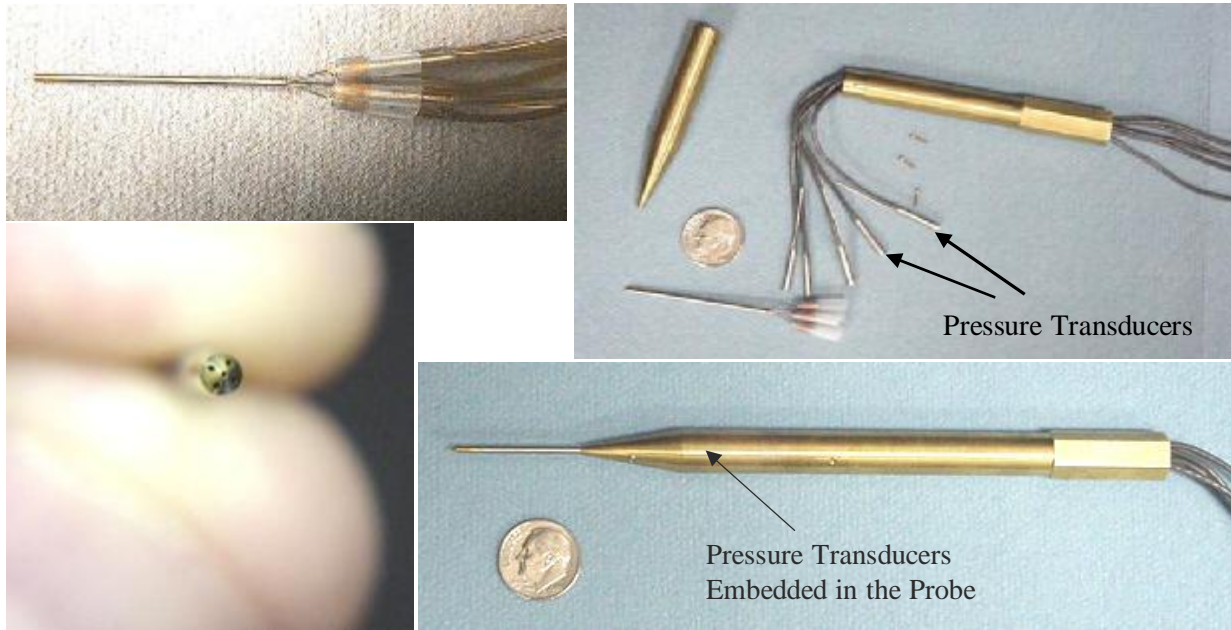
Cross-Sectional View of 5-Hole Probe with Transducers Embedded in the Probe Shaft.

Embedded Five-Hole Probe for Texas A&M University. Pressure Transducers are Embedded in the Shaft of the Probe. Tip Diameter is 1.6 mm.
Amplifiers for mV-Output Sensors:

Many of the sensors used in the fast-response probes have output of approximately 300 mV full scale. In order to minimize the effects of electrical noise, and to match input for data acquisition systems, Aeroprobe can provide a set of amplifiers. These amplifiers have military-accepted specifications, and can be used in most environments without loss of integrity or data accuracy. Gain and offset of the amplifiers are factory set.

Aeroprobe Amplifier Specifications

Characteristic	Value
Gain	G = 1 - 1000
Gain Error	0.25% Max (G = 100)
Nonlinearity	0.003% Max
Gain vs. Temp.	25 ppm/°C Max
Output	±10 V
Dynamic Response	100 kHz Min
Slew Rate	5 V/μs
Operating Temp. Range	-25°C – 85°C, -55°C – 125°C optional
Power Supply	9 – 18 V, 5 mA

Estimation of Accuracy for Multi-Hole Probes in Unsteady Flow:

There are two major sources of error that are specific to unsteady measurement of velocities with a multi-hole probe. First, there is the error due to the pressure attenuation (or amplification) that results from the need to use tubing to connect the pressures existing at the probe tip to the pressure sensors. Aeroprobe has developed a method to account for this error, which involves calibration of the tubing systems. Please see the section on tubing calibration below for more details.

The second source of error results from flow unsteadiness over a probe tip of finite size. Circulation, vortex shedding, velocity gradients, and flow inertial effects can cause significant errors between the true instantaneous static and total pressure in the flow and those measured by the probe. The most significant deviations from the steady flow result from flow inertial effects. In flowfields with high frequency content, multi-hole probes can be subject to large unsteady flow effects that must be accounted for to accurately predict the instantaneous three-dimensional velocity vector.

This objective of this section is to educate the probe user on the magnitude of the expected errors if a

hemispherical-tip probe is used in an unsteady flowfield *and no correction for inertial effects is applied.*

For a general, unsteady (not necessarily periodic) flowfield, the non-dimensional acceleration K is the parameter that indicates the expected errors. *The value of the non-dimensional acceleration coefficient is identical to the error in the estimation of the instantaneous dynamic pressure if the inertial effects are ignored*

K is defined as:

$$K = \frac{dU}{dt} \frac{R}{U^2}$$

where

U = Instantaneous Velocity Magnitude
 R = Radius of the Probe Tip.

Finally, the effect of unsteady inertial effects on the error in the prediction of the flow angles is much less than its effect on the velocity magnitude. For example, if the flow angles are low relative to the probe axis (pitch and yaw angles in the range between -20° and 20°), the errors made in the estimation of the flow angles, even for K values as high as 0.5, are less than 0.5%.

Example:

Consider a probe with $R = 1$ mm placed in an oscillating air stream at zero incidence angle. The flow is taken to be sinusoidal with a frequency of 2 kHz, with a mean velocity of 60 m/s and 30% amplitude. For this case, the calculated maximum K (corresponding to the point in the sine wave where dU/dt is a maximum) is 0.075, meaning that a maximum measurement error in the predicted instantaneous dynamic pressure of 7.5% is expected if the unsteady inertial effects are not accounted.

CALIBRATION SERVICES:

The probe calibration is essential to proper operation of the probe. It defines a relationship between the measured probe port pressures and the actual velocity vector.

The probe calibration process consists of placing the probe in a uniform, known flowfield (known in terms of velocity magnitude and direction, density, temperature, static pressure), and then rotating the probe to over 2000 different orientations with respect to the known velocity vector. The probe tip is maintained at the same physical location during the entire calibration process. At each orientation, the probe port pressures and the freestream dynamic pressure are recorded. In this way, a calibration map relating pressure and velocity is created.

Facilities:

The three main components of the probe calibration hardware are: the wind-tunnel facility that generates the known flowfield and the probe indexing system, which automatically positions the probe at a series of user-defined orientations and the pressure data-acquisition system. A calibration wind tunnel and probe indexer are shown in the figures below. The indexer is able to rotate the probe through a cone angle (θ) and roll angle (ϕ).

Aeroprobe uses four probe calibration facilities that combined have the ability to accommodate a wide range of probe designs, probe diameters (from 1.6 mm – 76.2 mm), calibration velocities (from 5 m/sec to 320 m/sec) and Mach numbers (0 to 0.95). Calibration speed range restrictions, dependent upon probe diameter, are specified in the table below.

Calibration Speed Restrictions for Various Probe Tip Diameters

Probe Tip Diameter	Calibration Velocity Range
1/16" to 1/4"	5 to 320 m/sec
3/8" to 3/4"	5 to 60 m/sec
1" to 3"	5 to 30 m/sec

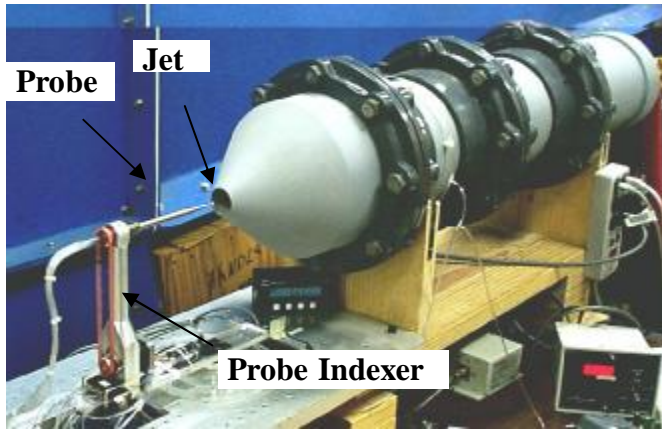

Calibration Facility with Probe Mounted on Indexer

Calibration Accuracy:

Pressure data acquisition during probe calibration is performed using different types of differential pressure transducers depending on the required pressure range, which is dictated by the range of velocities at which the probe is to be calibrated. The typical static accuracy of the transducers is 0.1% of the full scale reading. In order to minimize the effect of possible air temperature changes during a calibration, the transducers periodically undergo an automated zero-offset calibration process. The cone (θ) and roll (ϕ) positioning have resolutions of 0.9° , and are both equipped with rotational encoders, resulting in position accuracy on the order of 0.01° .

Multiple Calibrations:

If the user plans to use the probe over a wide range of speeds, Aeroprobe recommends that the probe be calibrated at multiple speeds. This allows our pressure-to-velocity reduction software (Multiprobe) to interpolate between multiple calibration files for increased ease of reduction and data accuracy. A typical calibration velocity schedule across the entire range of calibration facilities is listed in the table below. Calibrations spaced at $\Delta M = 0.1$ or less across the planned test velocity range are recommended.

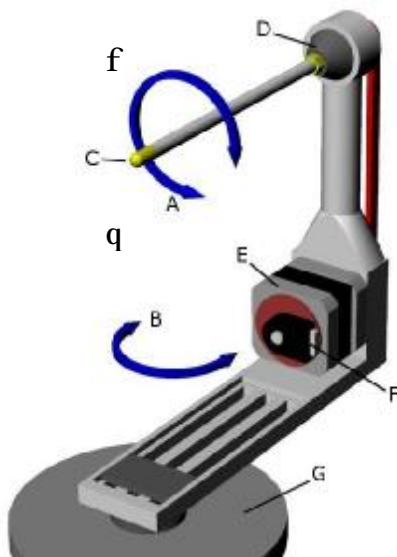

Typical Freestream Velocity Schedule for Entire Facility Range

Mach Number	Nominal Speed (m/s)
0.05	17.3 m/s
0.1	34.5 m/s
0.2	69.0 m/s
0.3	103.5 m/s
0.4	138 m/s
0.5	172.5 m/s
0.6	207 m/s
0.7	241.5 m/s
0.8	276 m/s
0.9	310.5 m/s

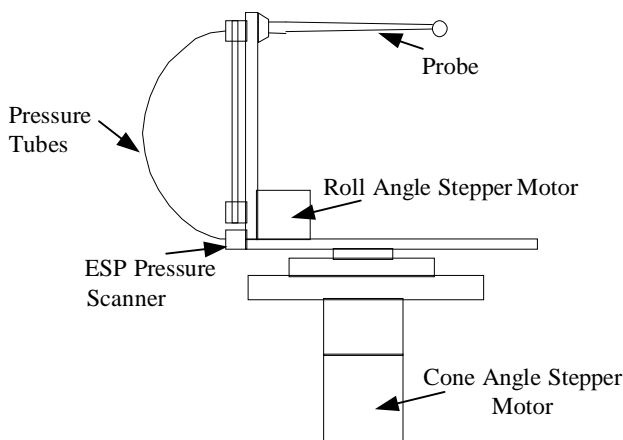

A Typical Probe Indexer Used to Position Probes in the Calibration Facility

ACOUSTIC CALIBRATION OF TUBING:

Because of the large uncertainty and tolerances in small diameter tubing systems, and the fact that assumptions necessary for theoretical treatment (such as laminar flow and circular cross-section) may not be satisfied, a calibration system was designed with the ability to accurately determine the frequency response of miniature tubing systems. This calibration system generates a repeatable fluctuating pressure at the inlet of the tubing system, while continuously monitoring the inlet pressure (p_s) and the pressure at the receiving end of the tubing system (p_r).

The loudspeaker is used to generate a sinusoidal pressure signal in the cavity with accurately set frequency and amplitude. Determination of the transfer function of the tubing system necessitates that the frequency be scanned through a range of values. At each separate frequency, the amplitude ratio p_r/p_s is calculated as well as the phase angle between the two signals. The calibration information obtained is used in the pressure-to-velocity reduction routine for fast-response probes to correct for the differences between the actual and measured pressure signals (see section on Multiprobe Reduction Software below).

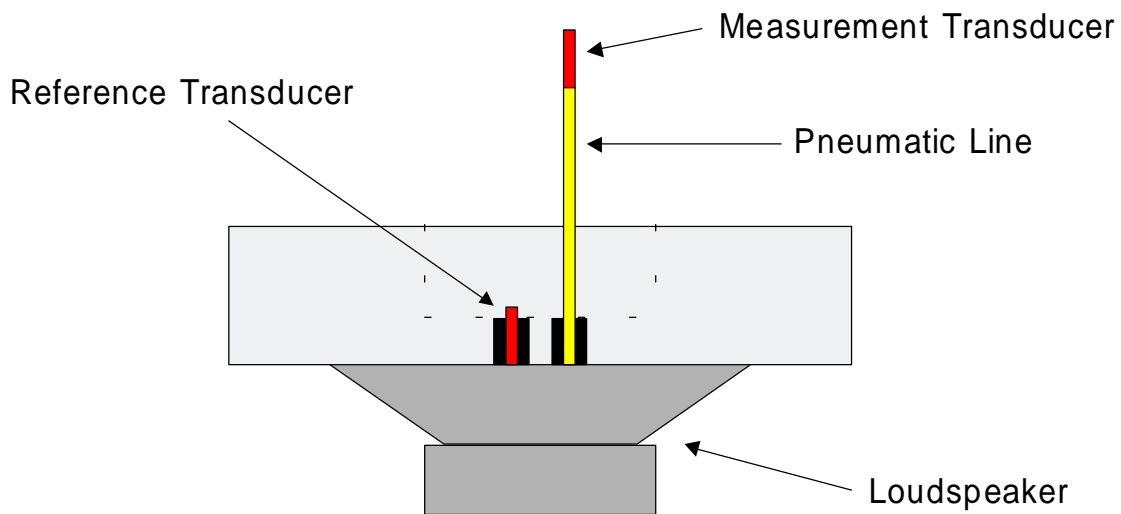

Calibration Facility to Determine the Transfer Function for Tubing Systems.

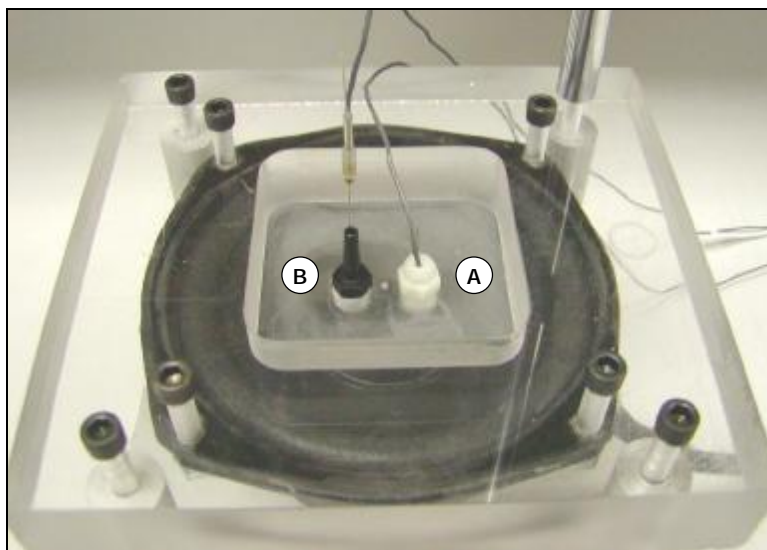

Picture of the Calibration System Assembly, A: The Reference Transducer Measuring the Input Pressure p_s and B: The Location of the Port for Tested Tube.

MULTIPROBE REDUCTION SOFTWARE WITH ACOUSTIC RESPONSE CORRECTION:

Multiprobe is a pressure-to-velocity reduction software package. The basic software is a post-processing, Windows-compatible package.

Multiprobe utilizes a local-least squares (LLS) fit of the closest (to the test point in question) calibration points, for each of the calibration variables. The LLS searching algorithm uses specialized multi-region search routines and angular range validation routines to improve accuracy. In addition, it can use a faster sector-fitting algorithm that is not as accurate as the LLS approach, but yields significantly higher data-reduction rates, which makes it more conducive to real-time data-reduction.

For processing of data from fast-response probes, Multiprobe uses an add-on package of routines that applies the calibrations of the tubing frequency response and pressure attenuation. Through a method in which FFT and deconvolution are applied, the tubing calibration data are used to process time-

series pressure data in order to recover accurately the actual pressures at the probe tip.

Multiprobe is a GUI front-end that retrieves user input and then calls functions stored in a DLL. This DLL is available to the user for programming customer applications and making pressure-to-velocity reduction calls from custom software. Current language support for C/C++, Delphi, Visual Basic, and scripts for Excel is included.

All reduction algorithms have typical average errors for steady flow of 0.8% (or less) in the velocity magnitude and 0.4° (or less) in the flow angles, when used with calibration data generated in our facilities. In addition, all reduction algorithms have the ability to interpolate between multiple calibration files. This gives the user the ability to operate the probe over a wide range of speeds while maintaining the reduction accuracy and ease of use normally associated with the use of one calibration file.

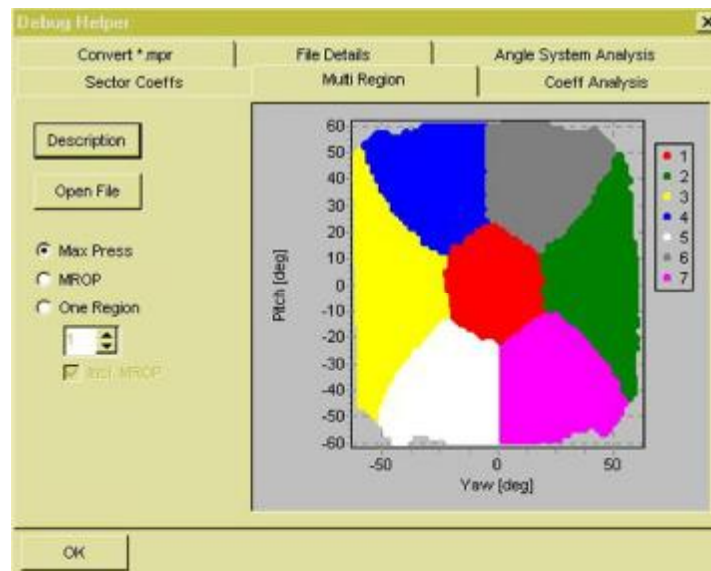

Multiprobe Pressure-to-Velocity Reduction Software

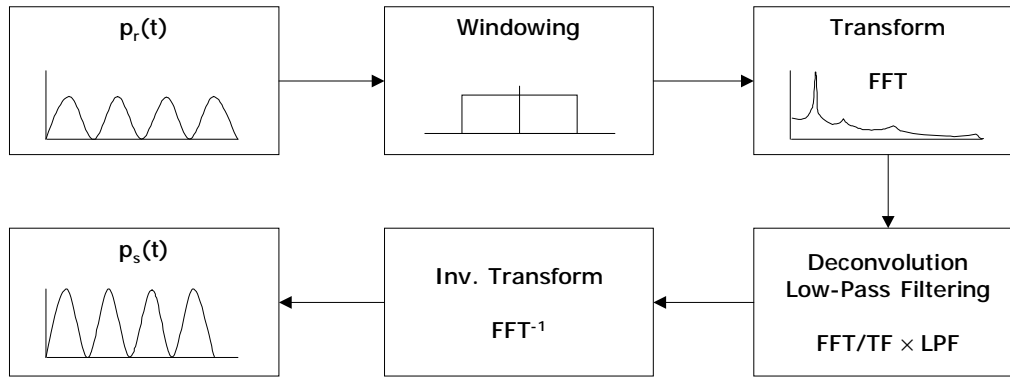

Flowchart for Pressure Signal Reconstruction from the Indicate Signal at the Transducer (P_r) to the Actual Pressure Signal Existing at the Probe Tip (P_s).

ADDITIONAL INFORMATION

Please refer to the multi-hole probe product information sheets for more details about probe geometry, probe calibrations and pressure-to-velocity reduction software for steady flows.

For information about other Aeroprobe products, please visit our website: www.aeroprobe.com.

REQUIREMENTS

Multiprobe software requires Windows 95/98, NT, 2000 or XP.

NOTES:

- Fast-Response Probes Include One Standard Calibration at a Speed of the Customer's

Choice (5 m/s – 320 m/s) if Probe Geometry Permits. **Specify Speed on Order!**

- Fast-Response Probes are Supplied with Tubing Calibrations that Specify the Acoustic Response of the Tubing Connections from the Probe Tip to the Sensors
- Fast-Response Probes are Manufactured Standard with 30 cm of Electrical Leads (Measured from End of Probe). Customer May Specify Longer Leads, but this May Affect Pricing.

ORDERING INFORMATION

Item	Description
FRC5E	Standard Cobra Five-Hole Fast-Response Probe (1+ psi, Specify Range; Calibrated, Specify Speed)
FRC5K	Standard Cobra Five-Hole Fast-Response Probe (5+ psi, Specify Range; Calibrated, Specify Speed)
FRC7E	Standard Cobra Seven-Hole Fast-Response Probe (1+ psi, Specify Range; Calibrated, Specify Speed)
FRC7K	Standard Cobra Seven-Hole Fast-Response Probe (5+ psi, Specify Range; Calibrated, Specify Speed)
FRL5E	Standard L-Shaped Five-Hole Fast-Response Probe (1+ psi, Specify Range; Calibrated, Specify Speed)
FRL5K	Standard L-Shaped Five-Hole Fast-Response Probe (5+ psi, Specify Range; Calibrated, Specify Speed)
FRL7E	Standard L-Shaped Seven-Hole Fast-Response Probe (1+ psi, Specify Range; Calibrated, Specify Speed)
FRL7K	Standard L-Shaped Seven-Hole Fast-Response Probe (5+ psi, Specify Range; Calibrated, Specify Speed)
FRS5E	Standard Straight Five-Hole Fast-Response Probe (1+ psi, Specify Range; Calibrated, Specify Speed)
FRS5K	Standard Straight Five-Hole Fast-Response Probe (5+ psi, Specify Range; Calibrated, Specify Speed)
FRS7E	Standard Straight Seven-Hole Fast-Response Probe (1+ psi, Specify Range; Calibrated, Specify Speed)
FRS7K	Standard Straight Seven-Hole Fast-Response Probe (5+ psi, Specify Range; Calibrated, Specify Speed)
Signal Amplifiers	
AMP5	5-Sensor Amplifier, for 5-Hole Fast-Response Probes
AMP7	7-Sensor Amplifier, for 7-Hole Fast-Response Probes
Signal Cables	
FRCAB5-10	Standard Fast-Response Probe-to-Amp Cable (10'), for 5-Hole FR Probe
FRCAB5-XX	Custom Fast-Response Probe-to-Amp Cable (XX'), for 5-Hole FR Probe
FRCAB7-10	Standard Fast-Response Probe-to-Amp Cable (10'), for 7-Hole FR Probe
FRCAB7-XX	Custom Fast-Response Probe-to-Amp Cable (XX'), for 7-Hole FR Probe
Probe Options	
TP5-7	1.59 mm Tip Diameter (Available in Brass Only)
SS5-7	Complete Stainless Steel Construction
Calibrations	
XCS	Extra Standard Calibration
SACS	Standard Setup and Acoustic Calibration of One Tubing System
SACS5	Standard Setup and Acoustic Calibration of 5-Hole Fast-Response Probe
SACS7	Standard Setup and Acoustic Calibration of 7-Hole Fast-Response Probe
Pressure-to-Velocity Reduction Software	
WIN-MP	Multiprobe w/Acoustic Response Correction Algorithm
WIN-ARC	Acoustic Recovery Software for Unsteady Pressure Signal Reconstruction
WIN-ATF	Acoustic Transfer Function Prediction (ATF) Software